

ISSUE 10 | FEBRUARY 2021

# METALS MAGAZINE

INNOVATION AND TECHNOLOGY FOR THE METALS INDUSTRY



**SEAMLESS SUPPORT  
THROUGHOUT 2020**

DIGITAL TRANSFORMATION  
IN METALS PRODUCTION

DISCOVERING THE CRACOW  
COMPANY LOCATION



**“ The challenging situation in 2020 also prompted unexpected rewards—and even some technological breakthroughs.”**



# EDITOR'S COLUMN

## DEAR READER,

I'll let you into a secret: I did not want to turn this issue of Metals Magazine into a "Covid edition." I felt that, by the time you held your copy in your hands, the pandemic might have taken its toll on you one way or another, and that you'd probably rather have Primetals Technologies discuss more positive subject matter. But as 2020 progressed, I realized two things. One, there was just no getting around what had become the "elephant in the room" in my concept for this edition. To not address the effects of this global crisis became more unfathomable as the year went on. Two, the challenging situation also prompted unexpected rewards—and even some technological breakthroughs. To give you an example: together with you, our partners in the industry, we developed new forms of remote collaboration using various kinds of digital tools. We were able to keep projects going and to execute equipment startups from afar. These achievements ensured business continuity for all of us, and while I believe that we'll be profiting from what we've learned for years to come, the new ways of working clearly originate from the situation we were facing—namely, Covid.

Having shared this story with you, I'd like to continue on a more personal note. Over the last few months, I have seen some darkness, but also much light. I have had friends struggle with isolation and with their mental health. I have seen colleagues worry about the wellbeing of their parents or grandparents. But I also know several couples who, having each been together for decades, finally decided to get married or to have children. It seems to me that the experience of 2020 has reminded us of the things that really matter. It has assured us that, after the darkness, there will be light. The cover of this magazine underlines this idea: if "charged" with UV-rich light, it glows in the dark. Let those close to you know that you care. And then, with that emotion, I suggest that you do what we all do best—pioneer the future of metals.

**Yours sincerely,**

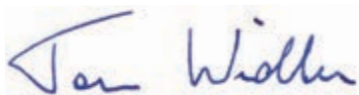

**Dr. Tom Widter**  
Editor-in-Chief of Metals Magazine  
metalsmagazine@primetals.com



**DR. TOM WIDTER**  
EDITOR-IN-CHIEF, METALS MAGAZINE



# 18 SEAMLESS SUPPORT THROUGHOUT 2020

03 **Editor's Column**

04 **Table of Contents**

06 **Message from the CEO**

08 **Recent Project and Company News**

## SPOTLIGHT

### 18 **Seamless Support throughout 2020**

Across the globe, 2020 had its challenges. Primetals Technologies helped to ensure business continuity.

### 26 **The Future of Metals Is Digital**

Digitalization has arrived at the metals industry, and we look at the multi-faceted implications.

### 34 **Living the Digital Transformation**

Metals Magazine visits the Primetals Technologies company location in Cracow, Poland.

### 44 **A Pioneer for Every Occasion**

At Primetals Technologies, we explore what's next. Learn more about six of our great innovators.

## TECHNOLOGY

### 52 **BOF Relining, Made Faster**

Primetals Technologies developed and implemented a new LD converter (BOF) relining solution at one of Ternium's steel plants, in Santa Cruz, Brazil.

### 58 **Making the Caster Mold Transparent**

Mold Expert, the innovative sticker-detection system from Primetals Technologies, has now been installed over 300 times in melt shops all around the world.

### 64 **The Full Potential of Cold-Rolling Mills**

Discover how experts from Primetals Technologies can unleash the full potential of any cold-rolling mill, making it easier to introduce new products.

### 70 **The Next Step in Long Rolling for Automotive**

Hyundai Steel has invested in two new, Industry 4.0 compatible long-rolling mills supplied by Primetals Technologies for its Dangjin, Korea, plant.

### 78 **Aluminum: The Metal of Kings**

Primetals Technologies continues its long tradition of pioneering superior solutions in aluminum rolling. A closer look at the metal's past, present, and future.





It felt like the world went dark when, in early 2020, the Covid-19 pandemic took hold. But Primetals Technologies' employees found new ways to stay connected to customers.

#### 84 **Plant Maintenance, Done the Easy Way**

Maintenance and Asset Technology (MAT) is designed to keep steel plants in perfect shape.

#### 90 **Connect Your Plants, Boost Your Results**

A new and groundbreaking method to connect, monitor, and service multiple plants remotely.

### INSPIRATION

#### 96 **Great Pioneers that Inspire us**

Who are the exceptional pioneers that inspire Primetals Technologies employees? This time, we discuss the achievements of Japanese mountaineer Junko Tabei.

#### 100 **The Pioneer's Guide to Boosting Creativity**

How can you best get the creative juices flowing—when working from home? Tips and tricks for maximizing productivity whilst you're away from the office.

#### 106 **Straight from the Labs of Primetals Technologies**

New innovations that are just around the corner, pioneered today by Primetals Technologies engineers. In this edition, we present a new R&D project in pickling.

#### 108 **How Will We Live?**

The series that aims to predict the future. This edition's focus topic is the use of hydrogen as a power source.

#### 114 **Ask the Expert**

Dr. Etsuro Hirai, CTO of Primetals Technologies, exclusively answers the questions you've sent in.

#### METALS MAGAZINE WEB ARCHIVE

Whether you're at work, at home, or traveling, you can always find a complete archive of Metals Magazine issues at [meta.is/magazine](https://meta.is/magazine)

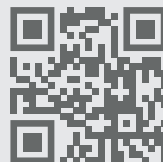

# MESSAGE FROM THE CEO

## DEAR CUSTOMER,

Let me first say that I hope this finds you well. 2020 has been an unusual year and a challenging one for many of us. Both in our professional and our private lives, Covid-19 has called into question many things we believed to be irrefutable. Now that 2021 has begun, some of the uncertainty still remains. When will the “new normal” begin? There is no one answer to this question as the world’s nations have tackled the pandemic differently and the final chapter to the story has yet to be written.

What is clear is that Primetals Technologies will continue to support steel producers across the globe in every way possible. Over the course of 2020, we established new methods of collaborating with our customers—be it via secure video link, augmented reality devices, webinars, or virtual conferences. We always aim to be as close to our valued partners as possible, and the recent events have not changed our commitment one bit. We are simply using new methods to connect, to stay in contact, and to ensure that our mutual projects continue to move forward.

I also think that these times serve as a reminder of three principles of universal importance—principles that everyone at Primetals Technologies chooses to take very seriously. The first is **solidarity**. The year 2020 placed a burden on many of us in the industry, and some of us have also experienced hardship. I am sure that taking care of loved ones is everyone’s highest priority, but looking out for friends, colleagues, and business partners who are struggling has become all the more relevant. I believe that solidarity will help our societies to recover from the effects of the coronavirus.

The second principle is **perseverance**. In the face of obstacles—of which we have seen a fair share in 2020—

it can be a lot harder to stay on course. It takes more energy to follow our hearts, and it becomes more difficult to remain true to our convictions. And yet it is vital that we remain dedicated, knowing that we will be rewarded if we walk the extra mile. Perseverance is a crucial quality, especially if you have a leadership role and people look to you for inspiration. I have found that staying visibly optimistic and determined makes a tremendous difference.

My third principle is that of **innovation**, because every crisis is also an opportunity for transformation and a potential catalyst for change. At Primetals Technologies, we have been using the past months—a time in which travel was often restricted—to advance the development of the solutions in our R&D pipeline. As you would surely expect us to, we have been focusing on pioneering what’s next in the world of metals—for instance, new and improved technologies in the fields of digitalization and green production. It is our ambition to innovate on your behalf and in partnership with you, in order to future-proof your businesses technologically, economically, and ecologically.

These three principles are also three promises that I can make to you today. Everyone at Primetals Technologies will do their best to listen carefully to the challenges you are facing, and we will support you to the best of our ability. We will do everything in our power to make our contribution to your long-term success. And we will keep on innovating so that we can offer you the best in consultancy, equipment, automation, and services—all of which will help you to stay ahead of the curve. I am convinced that through solidarity, perseverance, and innovation, the world of metals will have a bright future. Until we get there, we are here when you need us—whatever the circumstances. ●





**SATORU IIJIMA**  
CEO of Primetals  
Technologies

**“ I am convinced that through solidarity, perseverance, and innovation, the world of metals will have a bright future.”**

**Satoru Iijima**  
CEO of Primetals Technologies and Chairman of the Board



## — WITH — **PRIMETALS TECHNOLOGIES**

Primetals Technologies supports steel producers everywhere in the world with innovative solutions. Find out how—in our project and company news.



- |                                  |                           |
|----------------------------------|---------------------------|
| 1. Sutton, Massachusetts, U.S.A. | 9. Osmaniye, Turkey       |
| 2. Volta Redonda, Brazil         | 10. Chelyabinsk, Russia   |
| 3. Airing, Germany               | 11. Handan, China         |
| 4. Bolzano, Italy                | 12. Tangshan, China       |
| 5. Ranshofen, Austria            | 13. Shanghai, China       |
| 6. Steyr, Austria                | 14. Kurashiki City, Japan |
| 7. Tornio, Finland (see pg. 9)   | 15. Kakogawa, Japan       |
| 8. Ilyich, Ukraine               |                           |

Geographic locations of the project news topics discussed in this section





The remote operation profited from the mutual trust between the two partners.

Outokumpu's plant in Tornio, Finland, received new caster-automation systems.

## PROCESS-AUTOMATION SYSTEM FOR CASTER AT OUTOKUMPU TORNIO STARTED UP REMOTELY

**FINLAND:** Primetals Technologies has successfully completed the remote startup of a new Level 2 process automation system for continuous caster CCM1 at Outokumpu's Tornio site in Finland. The remote operation was greatly aided by the fact that caster CCM2 had been put into operation about six months prior. Much of the experience gained from the startup of CCM2 could be applied to that of CCM1, because of the similarities between both casters and thanks to the mutual trust between the engineers at Outokumpu and Primetals Technologies. In preparation for the procedure, experts from the two companies performed months-long tests, in which data from Level 1 and Level 3 systems was fed into the new Level 2 system in real time. As a result, by the time the final implementation took place, the new solution was already highly optimized. During the startup phase, experts from Primetals Technologies were on standby and were brought in via a live connection when the need arose. Afterwards, training sessions were provided.



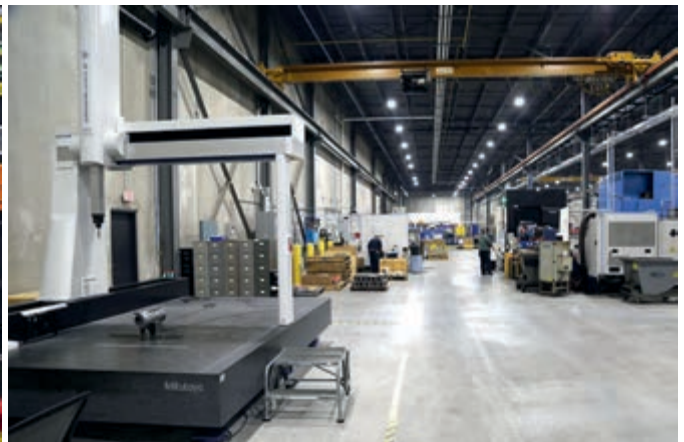

## COMPANY LOCATION FORMERLY BASED IN WORCESTER, U.S.A., COMPLETES MOVE TO SUTTON

**1. USA:** The Primetals Technologies company location formerly based in Worcester, Massachusetts, U.S.A., has now completed the process of moving to a new manufacturing and office facility in Sutton, which is some ten miles south of the previous site. The team reached its first significant move-in milestone when all office staff, including the engineering, sales, and research and development departments, transferred to the new building in July. The more complex challenge was to relocate the company's manufacturing operations. Primetals Technologies had operated on Crescent Street in Worcester for more than a century, gaining worldwide recognition for plant engineering and equipment manufacturing for the steel and non-ferrous metals industries under the name of Morgan. Now operating from Sutton, the location's employees are responsible within Primetals Technologies for engineering and manufacturing technologies involved in the manufacture of long products. This includes Morgan solutions such as reducing/sizing mills, controlled cooling systems, and high-speed laying heads, as well as wire-rod mills, finishing blocks, trim shears, and coil reforming, handling, and compacting systems. The digitalization portfolio includes smart sensors and control systems that monitor and collect data throughout the production process. Its domain extends from enterprise-resource planning through manufacturing-execution systems to control systems down to the plant-device level.



## Primetals Technologies provided engineering and advisory services to facilitate the implementation and startup of the new equipment.

### COMPANHIA SIDERÚRGICA NACIONAL RECEIVES AUTOMATION UPGRADE

**2. BRAZIL:** Primetals Technologies has executed a comprehensive revamp of the electrics and automation systems at the Presidente Vargas plant of Brazilian steel producer Companhia Siderúrgica Nacional in Volta Redonda. The equipment comprised motor-control centers, drives cubicles, auxiliary panels for voltage distribution, programmable logic controllers, a gas analyzer, the Melt Expert electrode-control system, and a data-acquisition system. The scope also included a heating, ventilation, and air-conditioning solution as well as a fire protection system that included a control panel, detectors, and valves. New cables and piping were laid during installation. The replacement of bad cables proved to be a critical step for the timely completion of the project. Primetals Technologies supervised the installation and the startup of the new equipment.



The electrics and automation system of the Presidente Vargas plant was modernized.



The new Red Ring Series 5 rolling stands will enable Stahlwerk Annahütte to reduce roll-change times. They are also easier to operate.

### STAHLWERK ANNAHÜTTE UPGRADES TO RED RING SERIES 5 ROLLING STANDS

**3. GERMANY:** Bavarian-based steel producer Stahlwerk Annahütte tasked Primetals Technologies with the revamp of two Red Ring Series 1 rolling stands, which were replaced with the newer Series 5 version. The existing stands were still working perfectly, but Annahütte chose to proceed with the upgrade because of the improved ease of operation, shorter roll-change times, and longer wear-part lifetime offered by Red Ring Series 5 stands. Primetals Technologies provided comprehensive engineering and advisory services to facilitate the implementation and startup of the new equipment. Operators were then trained to maximize the benefits introduced by the modernization. In addition to the new stands, Primetals Technologies supplied two standby rolling stands, a retrofit to the stand-lubrication system, and workshop systems used to prepare stands for production and to change rolls.



Primetals Technologies modernized the AOD converter at Acciaierie Valbruna in Bolzano.

## ACCIAIERIE VALBRUNA ISSUES FINAL ACCEPTANCE FOR REVAMP OF AOD CONVERTER

**4. ITALY:** Primetals Technologies has received the final acceptance certificates (FACs) from Acciaierie Valbruna for the mechanical and electrical revamp of the company's AOD converter at its production facility in Bolzano, Italy. The converter's trunnion ring and tilting drive were modernized to now include a shrink-fit connection. Primetals Technologies also implemented a new Level 1 process-control system and a Level 2 process-optimization system, which was fine-tuned to Acciaierie Valbruna's needs by experts from Austria via a remote connection. The new Level 2 system enables the digital integration of the AOD converter with other plant equipment, such as the electric arc furnace, ladle furnace, and the continuous casting section, where a dedicated Level 2 system from Primetals Technologies is already installed. The revamp has added stability to the production process, improved production flexibility, and reduced the maintenance efforts necessitated by the AOD converter.





## AMAG ROLLING TO MODERNIZE 2-HIGH AND 4-HIGH STANDS AT RANSHOFEN, AUSTRIA, PLANT

**5. AUSTRIA:** Aluminum producer AMAG rolling has placed two orders with Primetals Technologies for the modernization of production equipment at AMAG's Ranshofen, Austria, plant. The first project involves the upgrade of a 4-high cold-rolling stand and includes new gauge and flatness control systems, measuring instruments, Level 2 automation, as well as a coil-banding system and a marking machine. The second project will address the 2-high hot-rolling stand and center around the installation of new cyclo-converter equipment for the stand's main drive. The aim is to secure long-term spare-part availability.

## NEW INDUSTRIAL DEDUSTING SOLUTION DEVELOPED IN AUSTRIA NOW READY FOR PRIMETIME

**6. AUSTRIA:** In partnership with Kappa Filter Systems, Primetals Technologies is now offering metals producers a new dedusting solution. The technology achieves a pure dust concentration in the filtered off-gas of as little as 1 milligram per cubic meter—a value that is about 5 to 10 times lower than what other dedusting systems are typically capable of. The solution is constructed in the form of a stand-alone building, consists of massive concrete panels, and is emission-, sound-, and weatherproof. It is possible to integrate measuring and control rooms.



## PRIMETALS TECHNOLOGIES RECEIVES FINAL ACCEPTANCE FOR REVAMP OF PJSC'S 1,700-MM HOT-STRIP MILL

**8. UKRAINE:** PJSC "Ilyich Iron and Steel Works of Mariupol" has issued the final acceptance certificate (FAC) for the revamp of its 1,700-millimeter hot-strip mill. This modernization further increases the producer's competitiveness through the extension of product mix and range, improvement of quality, increase in productivity, and reduction in production costs. Capacity will grow from 1.36 to 2.5 million tons per year. Primetals Technologies was responsible for the engineering and the supply of core components for the hot strip mill, encompassing the installation of a new reversing roughing mill with heavy edger, a new coilbox, and the upgrade of the finishing mill.

**Tosyali will be able to produce everything from ultra-low-carbon to high-carbon steels, as well as peritectic and high-strength low-alloyed grades.**

## TOSYALI ORDERS EAF QUANTUM AND 2-STRAND CASTER

**9. TURKEY:** Turkish steel producer Tosyali Demir Celik Sanayi has placed an order with Primetals Technologies to supply an EAF Quantum, a twin vacuum-degassing plant capable of blowing oxygen, and a 2-strand slab caster for a flat-steels greenfield project in Iskenderun, Turkey. The EAF Quantum is designed to use a wide range of input materials of diverse quality and in various compositions—anything from scrap to HBI and hot metal. Its energy requirements are significantly lower compared to other EAFs, primarily thanks to its innovative scrap-preheating system. The twin vacuum-degassing plant provides additional treatment options for the steels produced. Because it can blow oxygen, Tosyali will be able to manufacture everything from ultra-low-carbon to high-carbon grades, as well as peritectic, API, dual-phase, and high-strength low-alloyed steel grades. The new meltshop will commence operation by the end of 2022.



The energy-saving EAF Quantum can use a wide range of input materials.



Mechel Group has successfully had its third LD converter (BOF) modernized at the company's Chelyabinsk Metallurgical Plant.

## THIRD BOF MODERNIZATION CONCLUDES AT MECHEL'S CHELYABINSK STEELWORKS

**10. RUSSIA:** Primetals Technologies has been issued the final acceptance certificate (FAC) by Mechel Group for the modernization of an LD converter (BOF) in the Chelyabinsk steelworks. The project's targets were to replace worn-out equipment, to further increase capacity by raising the tapping weight to 160 tons, and to optimize tap-to-tap times by shortening the blowing time. Thus far, Primetals Technologies has upgraded three converters installed at Chelyabinsk Metallurgical Plant, with the others having been started up in 2011 and 2013, respectively. The modernizations are part of an expansion program by Mechel Group that includes increasing overall annual production capacity. Primetals Technologies was responsible for the engineering and supplied core components including the vessel, trunnion ring, slag shields, and maintenance-free vessel-suspension system Vaicon Link.





HBIS Group has tasked Primetals Technologies with the installation of a KOBM converter.

## HBIS GROUP ORDERS KOBM CONVERTER FOR HANDAN STEELWORKS

**11. CHINA:** Primetals Technologies has received an order from HBIS Group's Handan Iron and Steel to upgrade an existing LD converter (BOF) in the steel plant in Handan, China, to a KOBM—a combined-blowing converter. Included in the order is a comprehensive automation system. Compared to a regular BOF, the KOBM converter features combined blowing of oxygen from the top and bottom. This results in better bath mixing, with metallurgical reactions staying closer to the equilibrium. In addition, the injection of lime ensures swift slag formation and excellent process and slopping control. Based on these benefits, HBIS Group expects to shorten the blowing process, to get closer to the carbon-oxygen equilibrium of the steel at tapping, improve yield by lowering the amount of slag and by reducing the iron oxide content in the slag, and to produce cleaner steels with minimal inclusions and impurities. This improved steel quality is expected to fully meet the requirements of the automotive industry. HBIS Group placed this order with Primetals Technologies because of its vast experience installing KOBM converters and thanks to its combined plant engineering, metallurgical, process-specific, and automation expertise. HBIS Group has been collaborating with Primetals Technologies for over 14 years. Together, the two partners have built new plants, upgraded existing ones, and advanced digitalization in steel production.

**HBIS Group placed this order with Primetals Technologies because of its vast experience installing KOBM converters.**



## HBIS TANGSTEEL ISSUES FAC FOR TWO NEW CGLS

**12. CHINA:** HBIS Tangshan Iron and Steel Group (HBIS Tangsteel) has awarded Primetals Technologies the final acceptance certificate for two continuous galvanizing lines (CGLs) installed as part of the expansion of cold-rolling mill No. 2 at its Tangshan plant in Hebei Province. The new CGLs have increased HBIS Tangsteel's production capacity for high-strength coated metal sheets by 650,000 tons per year. These sheets are used primarily by car-makers. The two lines were installed in a new hall next to the existing cold-rolling mill, which had also been supplied by Primetals Technologies. A special aluminum-silicon coating technology package was implemented on one line. Primetals Technologies was responsible for the engineering, manufacturing, and supply of the mechanical, electrical, and process equipment for both lines.

**The new continuous galvanizing lines were installed in a new hall next to the existing cold-rolling mill, which had also been supplied by Primetals Technologies.**

## BAOSTEEL ACCEPTS NEW AUTOMATION SOLUTION FOR CC3

**13. CHINA:** Primetals Technologies has received the final acceptance certificates (FACs) for a fully automatic dummy-bar top-feeding system for the CC3 2-strand continuous caster of Baoshan Iron and Steel Co Ltd. (Baosteel) at Steelworks No. 1 in Shanghai. This new solution enables operators to initiate the insertion of a dummy bar into the mold and the takeover from the hoist to the car by the push of a single button, with no further action required. Primetals Technologies installed several additional safety-related measuring systems—such as safety encoders, laser distance sensors, and safety-limit switches—so that the position of all movable components can be easily monitored. Prior to the implementation of the new system, Baosteel's operators had to personally supervise every step of the insertion of the dummy bar into the mold; the same was true for the takeover from the hoist to the car. These step-by-step processes were executed manually and involved careful checks that assured that all previous tasks had completed successfully. The new, automated sequence can be started from the casting platform or from the main control room, depending on choice and circumstances. Operators are now relieved of routine tasks and can simply monitor the progress of the fully automated sequence. In case of any problems, the staff can still intervene by stopping the sequence and switching to semi-automatic or manual mode. These modes can also be used for maintenance tasks. At the end of the automated sequence, operators only need to adjust the casting width of the adjustable mold.







## TOKYO STEEL TO IMPLEMENT IBOX FOR DESCALING

**14. JAPAN:** Steel producer Tokyo Steel placed an order with Primetals Technologies to revamp a continuous pickling line for hot-rolled strip at the company's site in Kurashiki City, Okayama Prefecture. The project scope comprises a tension-leveler-type scale breaker and an iBox pickling tank with acid-concentration control. This control mechanism addresses certain challenges with steel grades that are used for white goods or automotive parts—grades that may require two or three times longer to descale in conventional pickling lines compared to regular low-carbon steels. The iBox provides high descaling performance without the need for a circulation-heating or jet-pickling system. The revamp will increase Tokyo Steel's productivity with difficult-to-descale strip. It will also help the company to lower its energy usage and acid consumption.



## KOBE STEEL ISSUES FAC FOR UPGRADE OF PICKLING LINE

**15. JAPAN:** Primetals Technologies received the final acceptance certificate (FAC) for revamping continuous pickling line No. 2 at Kakogawa Works of Kobe Steel, a producer of high-value-added steels—primarily of long and flat products for automobiles, home appliances, ships, buildings, and bridge cables. Kobe Steel is also involved in a wide range of other businesses; it supplies non-ferrous metals such as aluminum, titanium, and copper for industrial machinery like compressors and isostatic pressurizers, as well as for construction gear. Based on this situation, Primetals Technologies had recommended that Kobe Steel make its iBox pickling solution a central part of the revamp. Another important aspect that prompted the recommendation of an iBox were the specifications of the pickling line at the Kakogawa plant: it is a continuous line that pickles hot-rolled strip of thicknesses from 1.8 to 6 millimeters and widths from 600 to 1,650 millimeters, at a maximum speed of 240 meters per minute and at a maximum throughput of approximately 300 tons per hour. Since the completion of the revamp, the newly installed iBox has demonstrated its capability to pickle high-strength strip for the automotive industry, save energy, and reduce acid consumption. The upgrade included the introduction of a polypropylene tank, which replaced the existing shallow tank consisting of acid-resistant bricks and steel plates, and is superior in chemical resistance and in terms of heat retention.

# SEAMLESS SUPPORT THROUGHOUT 2020

**2020 HAS BEEN A CHALLENGING YEAR ACROSS THE GLOBE. PRIMETALS TECHNOLOGIES STILL CONTINUED TO SUPPORT ITS CUSTOMERS IN THE METALS INDUSTRY IN EVERY WAY POSSIBLE.**





It felt like the world went dark when, in early 2020, many of the things we had taken for granted were called into question. The Covid-19 pandemic caused disruption in many fields, including travel, our working lives—and, by extension, the metals industry. 2020 became a time of challenge, but also of innovation: we found new methods to stay connected and get things done.

There are some eventualities you cannot really prepare for. And yet, when the Covid-19 pandemic broke, the world's nations reacted rather differently. Asian countries that had experienced the Sars outbreak in the early 2000s were faster to respond, as they had plans in place and were more open to using measures such as technology-backed contact tracing, placing the common interest above that of personal freedom. While every region tried to find the right balance between liberty and necessity, it soon became clear that new ways of working had to be established—new ways to collaborate with colleagues, business partners, and prospects.

“We got a sense that Covid was going to be a potential global disruptor in January 2020,” says Dr. Boguslaw Niedbała of Primetals Technologies Poland. The company location had sent a team member to China, which was about to place the region around the city of Wuhan into lockdown. “Our man caught the very last plane back to Europe, and getting him home was not easy. The airport staff in Cracow had to quickly figure out how to handle the unexpected situation. So did we.” Over the next few months, the whole of Primetals Technologies had to find new solutions for ensuring business continuity—and for keeping its customers happy. »



As 2020 unfolded, the full scope of Covid-19 became more and more evident. At the start of the year, the WHO declared the outbreak a “public health emergency of international concern;” in March, the same body proceeded to classify it as a pandemic. Like many other companies, awareness within Primetals Technologies grew, with various measures being taken—depending on the situation in the respective country. Of course, staying connected with customers and business partners was of the utmost importance—but so was ensuring the personal safety of everyone involved. In order to optimally support steel producers during the pandemic, the staff of Primetals Technologies came up with a mix of solutions, from traveling under special safety precautions through hosting informative webinars to executing remote startups. The objective was always to provide the best-possible support to all of the company’s customers, in spite of the challenges at hand.

### A TRIP LIKE NO OTHER

Andreas Zahrhuber is one of about 50 Primetals Technologies employees who chose to travel to China, even though it meant having to undergo a 14-day quarantine period upon arrival. It was not the easiest trip to begin with, he remembers, and the endeavor certainly did not feel normal: “When I arrived at Vienna Airport, it was all but empty. The same was true in Zurich, from where I was going to depart to China.” But boarding the plane to Shanghai proved challenging. It was not enough to have

his documents ready; Zahrhuber had to complete an additional online registration form that had trouble accepting his email addresses. Only after this issue was resolved could he proceed to the gate. Thanks to the lengthy waiting period in Zurich in between flights, he was able to get everything sorted out in time.

For the entirety of the trip, Zahrhuber wore a face mask. Once the plane had made it onto Chinese soil, he went through several checkpoints, each of which made sure he was eligible for entry. This was then followed by a coronavirus test. After a certain waiting time, he was taken to a quarantine hotel by bus; his luggage was thoroughly disinfected before it was handed back to him. What followed were 14 days of isolation—something that Zahrhuber had mentally prepared himself for. “I told myself that two weeks was not that long, compared to what other people were experiencing. I developed a strategy for what I would concentrate on. Thanks to this mentality, I managed quite well.”

As of December 2020, Zahrhuber has been tested for coronavirus no fewer than five times. “I will have been tested a sixth time by the end of the year,” he says. While in China, he would carefully adhere to all required safety measures and hygiene protocols—even in workshops. Looking back at the trip, Zahrhuber feels that he did what was necessary to keep his project going. Would he do it again—face quarantine abroad?

## TRAVELING IN THE TIMES OF CORONAVIRUS

**Covid-19 has made it harder to travel safely for everyone, including Primetals Technologies employees. But sometimes, a project necessitates physical presence at a customer’s site, and certain business meetings can’t be held remotely. Andreas Zahrhuber, who manages iron- and steelmaking projects, is one of around 50 Primetals Technologies specialists who endured the difficult travel conditions and willingly underwent a 14-day quarantine period in the destination country.**



Vienna Airport is almost deserted. While it looks abandoned, some flights were still taking off.

Security personnel, disinfecting luggage. This was mandatory before entering the quarantine hotel.



## The objective was to continually provide the best-possible support to customers, despite the challenges at hand.

“Sure—if a customer or business partner required me to travel in order for the project to be a success,” he says.

### REMOTE COLLABORATION

On many occasions, the staff of Primetals Technologies found ways to continue or even to complete projects from afar, using tools such as video connections, augmented reality applications, industrial headsets, and smartphone cameras. Jürgen Meisel is part of a team that implements advanced mechatronics solutions for

continuous casting—the mold-monitoring and break-out-prevention system Mold Expert and the soft-reduction technology DynaGap being two prominent examples. “We have successfully completed remote startups together with customers in Romania, Russia, China, and Taiwan,” he says.

Steel producers have recently become more open to allowing Primetals Technologies limited access to their network infrastructure, finds Meisel. “We have a secure and reliable method of using a customer’s Internet framework to connect to our company locations,” he says, and explains that working with steel-plant operators remotely changes the entire process of starting up new equipment. There is more preparation work involved to minimize the scope of the actual on-site tasks: “We have always tried to have our products follow our ‘connect and cast’ philosophy, but the trend toward remote startups has made us double down on keeping implementation times as short as humanly possible.”

Meisel suspects that, even after the pandemic, remote collaboration will continue to be the preferred option in a number of scenarios. “We will certainly travel less,” he says. Will he miss being on the road? “There is something quite special about meeting people face-to-face. For some 20 years now, I have been in regular contact with plant operators around the world, doing hands-on work with them. These days, I sometimes miss the »



14 days can feel like a long time when all you have is a few square meters of hotel room space.

Finally, after two weeks of waiting (and working from the hotel), the first meeting took place.

## While direct experience is the best way to learn, the webinars offered by Primetals Technologies represent another excellent pathway to gaining specialist knowledge.

### WEBINARS FOR INDUSTRY EXPERTS

In an effort to provide industry experts with specialized knowledge, Primetals Technologies has begun to offer a wide range of webinars free of charge. Whilst some webinars are live events, others are available “on demand” and can be accessed whenever convenient. All sessions are hosted by Primetals Technologies representatives, who are joined by additional high-profile speakers from partner companies.

Topics include:

- Plant optimization for carbon footprint reduction and greater efficiency
- IT infrastructure for the execution of remote startups
- Remote startup of a Level 2 automation system in continuous casting
- Ideal use of augmented reality and smart glasses
- Software-as-a-service (SaaS) solutions in 2020
- The future of Arvedi Endless Strip Production
- Introducing digitalization into sinter plants
- Hybrid plate-cooling technologies



#### ATTEND OUR WEBINARS

To access our free webinars, point your web browser to the link below or scan the QR code to the left.

[meta.is/webinars](https://meta.is/webinars)

immediacy—the joy when you succeed together and when everyone goes to have dinner to celebrate.” But it is clear, Meisel finds, that safety comes first—and that the future will be more digital than the past. “It is a positive development overall,” he says.

#### AUGMENTED REALITY

Melt Expert, an innovation that ensures optimal energy use for electric arc furnaces and which optimizes the furnaces’ electrode consumption, is another example of a technology that was frequently implemented via remote collaboration during the 2020 pandemic. Christian Koubek is one of those responsible for facilitating the new approach: “We have already completed projects in Brazil, China, India, and several states in the U.S.A.,” he says. “We approached colleagues from Primetals Technologies who live and work in the customers’ regions and trained them so that they could execute the on-site tasks. Our experts from Austria were then brought in via video conferences, secure messenger apps, and remote connections. We also used augmented reality to ensure that everyone was on the same page.”

On average, startup time took seven to ten days, depending on the circumstances—about the same duration as that of “normal” startups. There was the added benefit, however, of simplified communication: Since the local Primetals Technologies employees spoke the same language as the plant staff, they were able to act as both technicians and translators. Over time, Koubek expects that his colleagues from other locations will gain enough experience to make an even greater contribution to future startups and support customers in the long term with expert knowledge. “This development will greatly improve our overall customer service,” he says.

#### DIGITAL DISCOVERY

While direct experience is arguably the best way to learn, webinars represent another excellent pathway to gaining specialist knowledge. Primetals Technologies has begun to offer live as well as “on demand”-type »



## REMOTE STARTUPS OF EQUIPMENT AND AUTOMATION

Necessity is the mother of invention—never more so when the whole world faces the same challenge. During 2020, Primetals Technologies teamed up with many of its customers to pioneer the solutions required to start up production equipment from afar. It became a new way to collaborate that deepened the relationships with metals producers worldwide.

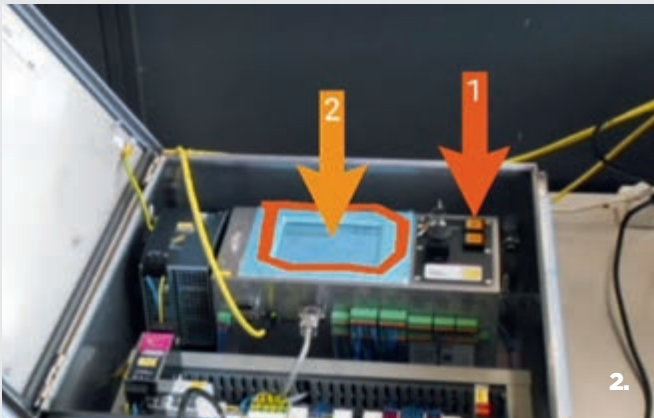

**FIG. 1:** Celebration after a successful startup. The Austrian-based Primetals Technologies employee (upper left) was working from home and joined the local on-site team via secure video link.

**FIG. 2:** Augmented reality solutions make it easier to indicate what procedures need to be done, and where. The image shown here is the screenshot of a livestream from an on-site worker's viewpoint.

**FIG. 3:** On the other end of the video connection, far-away experts are able to participate straight from their offices—and give advice on how to take the next steps by providing augmented reality hints.



## Coronavirus has kept many of us apart; having now bridged that gap using new methods of collaboration, we will soon stand closer together than ever before.

webinars, all of them free of charge. As of late 2020, over ten webinars are already available, with more to follow in 2021 and beyond. Topics cover the digitalization of sinter plants, remote support using smart glasses, the application of artificial intelligence in ironmaking, and much more. Two important focus areas—aside from digitalization—are cost optimization in steel production and effectively lowering a plant’s carbon footprint.

All webinars are hosted by Primetals Technologies staff; the speakers include experienced specialists from the company as well as select third parties. The external contributors add another layer of information to the presentation and introduce an additional outside perspective for a more well-rounded and complete view of the subject matter of the respective session. If a specific webinar raises further questions or simply piques a viewer’s interest, they are invited to request a follow-up conversation with a sales or solutions expert.

### THE FUTURE OF CONFERENCING

Another future-oriented initiative for providing information to steel producers and for enabling them to extend their global business network is the Virtual Conference Center (VCC) of Primetals Technologies. The VCC is different from webinars in that it is a comprehensive emulation of an actual “live” event, where attendees can not only listen to keynote speakers but are also able to have impromptu meetings if they encounter someone they want to spontaneously exchange ideas with. Everybody gets to set up an avatar—a virtual version of themselves—and can then move freely within the conference center. Depending on the participant’s location within the environment, they will hear the people around them in stereo sound. There are dedicated “green zones” that allow for private conversations, which can’t be listened to by anyone outside of the area.

The VCC will be rolled out over the course of 2021 and is sure to establish itself as a new form of international thought exchange and networking. At the time of writ-

ing, Primetals Technologies is refining the solution to make it ready for primetime. When complete, the VCC will feature a main conference hall, several breakout rooms, an information center, an outdoor recreational area, and of course the aforementioned private zones—possibly also some surprises. It won’t be replacing “real” in-person events after the pandemic, but it will certainly extend the possibilities of meeting other professionals from the metals industry.

### LEARNING FROM 2020

Covid-19 has brought about many changes—some large, some small, some temporary, and some permanent. Still, the future will be what we make of it. One day, hopefully in summer 2021, the world of metals will be able to fully resume its path toward even greater efficiency and environmental compatibility. It will continue its journey toward comprehensive digitalization. But it will also have gained important insights from the challenging year that was 2020. Many companies—including Primetals Technologies—have discovered the potential of having their white-collar employees work from home at least part-time. Many have found new methods of collaboration between their own company locations but also with suppliers, consultants, and other industry partners. Many have found that the crisis has made them stronger as their teams have shown immense cohesion, great perseverance, and tremendous solidarity in spite of having to social distance, to wear face masks, and to follow stringent health and safety protocols.

Primetals Technologies has used 2020 to pioneer, to extend, and to refine new ways to stay in touch with metals producers all around the world. The company will use what it has learned from the experience of Covid-19 to further improve its customer service and to provide even faster support thanks to the tools and techniques described in this article. For many months, Covid-19 has kept mankind apart; having now bridged that gap using new methods of collaboration, we will soon stand closer together than ever before. ●



## VIRTUAL CONFERENCE CENTER

Covid-19 has meant that most major industry conferences in 2020 had to be cancelled or postponed. However, the pandemic also demonstrated what's possible in the world of bits and bytes. Primetals Technologies has developed its very own Virtual Conference Center (VCC), which will host get-togethers of up to 40 people from 2021 onward. It will facilitate international communication and collaboration. Participants need nothing more than a personal computer running Windows and a headset. The VCC provides a set of environments where visitors can interact with one another and exchange ideas after attending the conference. It is a multi-layered, immersive experience and even allows for private conversations in dedicated "green zones."



**FIG. 1:** This large area enables participants to meet up and to have private conversations in the special "green zones". The main presentation room is accessible by the gate in between the two media walls.

**FIG. 2:** The VCC is a full-fledged representation of a physical event center with all the bells and whistles one would expect. Attendees can enjoy the recreational area outside of the building, which includes sofas.

**FIG. 3:** Seminar rooms allow for breakaway sessions. Each room features whiteboards, cards, stickers, and more. If desired, the results can then be shared with other visitors via the media walls in the main area.



# THE FUTURE OF METALS **IS DIGITAL**

Digitalization is changing metals production, and Covid-19 has accelerated the transformation that will ultimately turn today's steel plants into fully automatic "smart factories." Primetals Technologies is pioneering smart solutions, systems, and services to support steel producers on their path toward more efficient, more stable, and less labor-intensive operations.

The steel industry is undergoing digital transformation toward smart production.





For the steel industry, digital transformation has many faces. The ultimate target may be the “fully automatic plant,” but how do we get there?





In today's world, there are four megatrends—trends that can be observed on a global scale—with immense relevance to the steel industry. The first megatrend is mass urbanization, which is particularly evident in countries that are still developing. There are many reasons why more people decide to relocate to cities, the most common being economic in nature. It was much easier for people in the 19th century to make a living in London than in most other places of the U.K., and so they chose to move there. The same is true for modern-day Shenzhen in China—and there are many more examples. As a consequence, the need for housing increases and the general infrastructure and economy of a city changes as it grows and transforms. Ultra-high building will become more common in the next few decades. Steel will be one of the most important base materials in the resulting construction projects.

The second megatrend is that of increased mobility and the transition from internal-combustion-engine cars to electric vehicles. The Covid-19 pandemic has temporarily impacted worldwide car sales, but in the long run, travel restrictions will ease and the desire of individuals to become mobile will rise again. Electric vehicles are gaining prominence in many countries, partially thanks to tax incentives and governmental subsidies. California, in September of 2020, doubled down on its efforts to reach carbon-neutrality when Governor Gavin Newsom signed an executive order requiring all new passenger vehicles sold in the state to be zero-emission by 2035. In the future, advanced high-strength steels and electrical steels will be in much higher demand, which will allow the car industry's evolving needs to be met.

The third megatrend is global climate action. The Paris Accord in 2015 set the scene, and while the global community—with the exception of a few nations—is racing to meet the ambitious goals, the size and scope of the challenge is also becoming clearer. Action is clearly being taken, and regulations that ensure the greener future of industry, transport, and our lives in general will become more stringent. Carbon taxes are expected to rise in many countries, and technologies based on the use of renewable energy rather than on

## Why has the metals industry been comparably slow to embrace the new opportunities that can be generated with digital solutions?

### WHAT DO DIGITAL SOLUTIONS ACHIEVE?

- Greater stability in the production process
- Higher yields
- Faster product development
- Greater adaptability to changes in market conditions
- More agile reaction to changes in raw-material availability
- Reduction in labor and production costs

fossil fuels will contribute to greater sustainability across the board. For the steel industry, this means that it will have to change the way it operates in order to achieve much lower emission targets.

### STEEL FINALLY GOES DIGITAL

Lastly, the fourth megatrend is digitalization, which is different from the other megatrends in that it is not only an important trend in itself, it also permeates all the other megatrends, acting as an enabler and a catalyst for change. Importantly, digitalization is not limited to information technology, although it is clearly most evident in this context because this is where its origins are. It led to the creation of new digital tools and solutions, which transformed one sector after another and prompted the development of new business models. As of 2020, digital transformation has disrupted the media and entertainment industries (from optical media to streaming), to retail via online shopping, to telecommunications through the smartphone, to finance by virtue of crypto currencies, to manufacturing thanks to technologies such as 3D printing, to the automotive industry with self-driving cars, and to health care with e-health devices and big data backed diagnosis. Now, similar changes are taking hold in industries responsible for producing basic materials—such as the steel industry.

So why has it taken so long for digital transformation to arrive at the steel industry? Why has metals production been so slow to embrace the new opportunities that can be generated with digital solutions? Of course, it must be noted that metals-production facilities for a long time have been highly automated. However, the orchestration of individual production units was incomplete, and artificial intelligence and advanced knowledge-management systems were not part of the picture; neither were smart sensors, mechatronics, or robotics at a level of sophistication that we





## TANGSTEEL'S RISE TO THE TOP

Over the course of a 6-year partnership with Primetals Technologies, Tangsteel has profited from the capabilities of Through-Process Optimization and other digital solutions. The producer successfully changed its product mix and became a certified supplier to many automotive companies in China and beyond:

- Volkswagen Skoda
- BMW Brilliance
- Changan Ford
- Shanghai General Motors
- SAIC Motors
- Foton Automotive
- Great Wall
- GAC Group
- Aion
- NEVS (SAAB)
- FEW Haima
- SAIC-IVECO Hongyan
- Faurecia
- Bosch
- Geely

are seeing today. Data analytics, combined with great metallurgical expertise, can help digital transformation to unfold in a way that was previously unattainable. The main reason for the delayed adoption of digitalization in the metals industry is that interconnecting the different units of a steel plant is no simple task and there are no “out-of-the-box” solutions that could instantly be put to work without customization. Also, technology in metals production has to work extremely reliably—much more so than a smartphone app, which can always be updated to iron out any bugs.

### THE SMART PLANT OF THE FUTURE

For the steel industry, digital transformation has many faces. The ultimate target may be the “fully automatic plant,” but how do we get there? The answer is a combination of factors, namely smart sensors, advanced

automation, robotics, mechatronics, and increased use of artificial intelligence, which all contribute to making steel production less labor-intensive. The tasks that still depend on human workers are greatly aided by digital assistants, which simplify the decision-making process by providing guidance on how to resolve any unexpected issues.

The Covid-19 pandemic has also highlighted the importance of remote work. Thanks to video conferencing, remote connections, augmented reality, and other advances in technology, it is easier than ever to collaborate from a distance. Primetals Technologies is now capable of providing steel producers with seamless support throughout every stage of a project by sending experts to the plant’s location—and from afar, using new digital tools. In the year 2020, the engineers



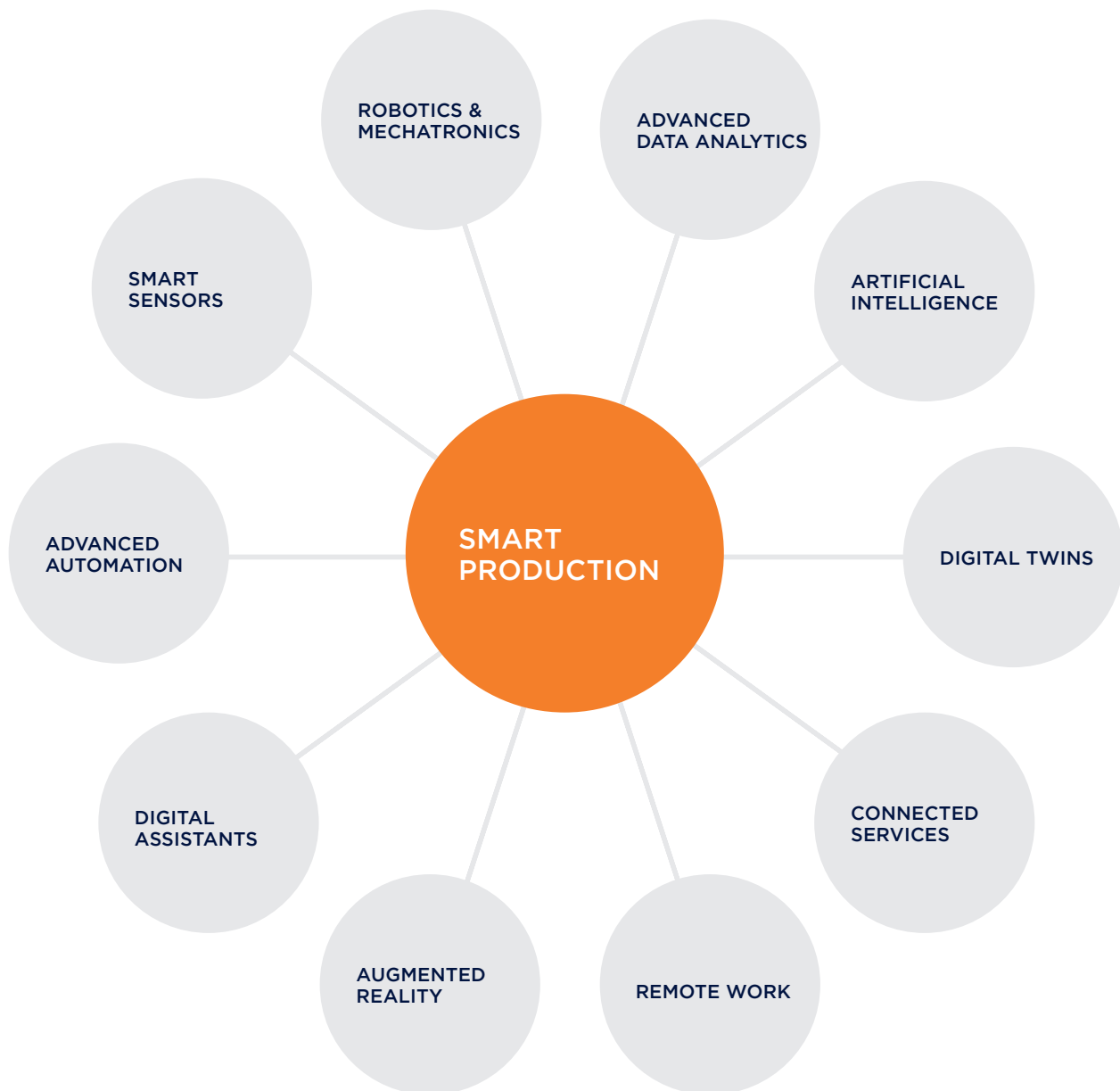

and solutions experts of Primetals Technologies have provided more online live support than ever before to steel producers all around the world—almost everything from initial consultation to the startup of new equipment was executed remotely if the customer so desired.

### **BENEFITS FOR PRODUCERS**

For steel producers, digitalization makes “smart production” a new reality—with many decisive benefits: higher yields, smaller lot sizes without penalties in efficiency, increased throughput, and a reduction in human labor—the increase in efficiency prompted by digital technologies brings about significant cost savings. There is an improvement in worker safety, and thanks to predictive-maintenance solutions, equipment reliability is higher as well, with less unplanned downtime as a result. Productivity is also increased, and it becomes easier to react to any external changes such

as shifts in the availability of raw materials. Product development is another important area, and with the right digital technologies in place, the time to market for newly developed steel grades is far shorter.

Digitalization can introduce greater transparency across the production chain and help to build up and preserve the expert knowledge required to make portfolio adjustments. This aspect of knowledge preservation and application is a crucial aspect of digitalization in metals production, and Primetals Technologies has pioneered solutions such as Through-Process Optimization (TPO) to enable steel producers to raise their game and take their businesses to the next level.

### **THROUGH-PROCESS OPTIMIZATION**

While TPO is only one key element of the digitalization portfolio of Primetals Technologies, its capabilities per-



## Never before has the digitalization of expert knowledge in steel production been a more crucial part of the industry's innovation roadmap.

fectly demonstrate the many advantages of digitally enhanced steel production. The basis for TPO is large amounts of data generated across the entire steel-production chain, from agglomeration to the coiling of the processed strip. This data is then fed into a dedicated IT system that uniquely combines machine learning and big data processing with digitalized metals-production expertise. This combination is essential, because even the most advanced artificial intelligence technologies around today would still not be smart enough to know “what to look for”—the data points that really matter. TPO has a built-in real-time prediction functionality that calculates the mechanical properties for the entire strip length and which warns of any potential product-quality issues. There is less need for sampling and testing the product because of TPO's automatic grading capability, which increases overall yield.

TPO provides steel producers with the KPIs that are essential in terms of ensuring a high degree of process stability and process efficiency. Developing new steel grades becomes easier and faster. While TPO can be a great enabler when a producer wants to begin manufacturing higher-quality steels, such as advanced high-strength steels (AHSS) or pipe grades, moving up the quality ladder is not necessarily the only reason to use TPO. Sometimes, market conditions require a producer to take a new direction and transform a plant into one that makes slightly or even substantially different products. TPO significantly speeds up such transitions and helps producers to optimize their product mix according to the requirements of their respective markets.

### DIGITALIZATION PARTNERSHIPS

One steel producer who adopted TPO in order to make a wholesale upgrade to its product portfolio is Chi-

nese-based Tangsteel. With its sights set on becoming a supplier to the automotive industry, Tangsteel partnered with Primetals Technologies to comprehensively upgrade its facilities (see the box below for our earlier article) and implement TPO. Over the course of six years, 20 processing units were connected to the TPO system, amounting to more than 10,000 signals—most of them high-resolution. No fewer than 132 KPIs were set, allowing Tangsteel to track plant productivity and other factors with greater accuracy than ever before.

What were the results? Impressively, Tangsteel was able to obtain certifications to supply car makers such as Volkswagen's Skoda, BMW's Brilliance, Changan Ford, General Motors, SAIC Motors, Foton, and many more. Several new steel grades were developed, such as DP600 to DP1200, and Tangsteel also learned to apply new coatings: galvanized, aluminum silicon, zinc magnesium, and others. Primetals Technologies provided Tangsteel with a powerful solution for the detection of surface defects and for root-cause analysis—a solution that is part of the IT system belonging to TPO.

### PIONEERING THE DIGITAL FUTURE

The future of metals is digital, and Primetals Technologies will continue to pioneer digitalization in steel production—with new tools, solutions, and services designed to enable steel producers to stay ahead of the curve and to target the market segments that suit them the best. Covid-19 has certainly acted as an accelerator in this context. Never before has the digitalization of expert knowledge in steel production been a more crucial part of the industry's innovation roadmap; never before have remote connections, augmented reality, and seamless support been so much at the forefront of international collaboration; and never before has the fully automatic plant been closer to reality than it is today. But we are not quite there yet, and further pioneering work and long-term partnerships will be required as we take our next steps. ●

**Dr. Thomas Pfatschbacher**, Head of Digital Transformation and Smart Production

**Dr. Tom Widter**, Editor-in-Chief, Metals Magazine  
(Both with Primetals Technologies Austria)

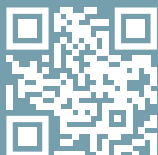

#### FURTHER READING

Learn more about the collaboration between Tangsteel and Primetals in Metals Magazine 02/2018.

[meta.is/Tangsteel](https://meta.is/Tangsteel)

# FOUR SCENARIOS OF DIGITAL TRANSFORMATION



## 1. SPECIAL STEELS PRODUCER

Capacity: 200,000 tons per year

Region: North America

### Challenges:

- Quality control is labor and time intensive
- Product quality variable (reasons unknown)
- Inventory too large; late order fulfillment

### Smart solutions:

- Through-Process Optimization (TPO) allows for the digitalization and automation of proprietary metallurgical knowledge applicable to specialty-steels production. TPO adds transparency to the production process and enables automatic optimization.
- The robotic solution LiquiRob, which is capable of automatic sample-taking at the EAF, provides more accurate measurements. This will help to stabilize product quality.
- Because of the extensive product portfolio and usually small order sizes, a state-of-the-art production-management system is required. A logistics study will reveal any production bottlenecks and will help to increase overall efficiency.

Through-Process  
Optimization



[meta.is/tpo](https://meta.is/tpo)

Production-  
Mgmt. System



[meta.is/pms](https://meta.is/pms)



## 2. RAIL & LONG STEELS PRODUCER

Capacity: 450,000 tons per year

Region: Europe

### Challenges:

- Does not reach desired quality levels
- Production process unstable and inefficient
- Experienced employees will be pensioned

### Smart solutions:

- TPO will ensure that the targeted quality levels can be reached and maintained. TPO data scientists, metallurgists, and process experts help to identify any weak points.
- The Asset Life Expert (ALEX) of Primetals Technologies is an advanced condition-monitoring system for all production equipment and features "smart assistant functions." Its predictive maintenance functionality optimizes equipment lifetime and contributes to proper productivity and efficiency levels throughout the plant.
- Preserving the expertise of seasoned workers is a challenge that can be met with TPO, which is capable of digitalizing and managing metallurgical and operational know-how.

Through-Process  
Optimization



[meta.is/tpo](https://meta.is/tpo)

Asset Life  
Expert (ALEX)



[meta.is/alex](https://meta.is/alex)



Every metals producer has specific goals—and faces unique challenges. Depending on factors such as a producer's portfolio, production equipment, and market conditions, the potential of embracing digital transformation varies greatly from case to case. The digitalization experts at Primetals Technologies strive to learn exactly where metals producers are coming from, what their needs are, and where they want to take their business. From consulting to the implementation of modernization packages and the provision of (remote or on-site) metallurgical services, Primetals Technologies covers all aspects of the digital future of metals production—and supports its customers with cutting-edge digital innovations in any scenario.



### 3. FLAT STEELS PRODUCER

Capacity: 4.8 million tons per year

Region: Asia

#### Challenges:

- Intends to target automotive and AHSS
- Plant capabilities need to be analyzed
- Product development and certification

#### Smart solutions:

- A market analysis will indicate which markets will be the most viable. Primetals Technologies can provide multi-layered technological and strategy-oriented studies.
- The entire production chain—from steelmaking to annealing and coating—needs to be reviewed. On the basis of this analysis, the steel producer can decide the most appropriate upgrade path and can set the right priorities in product development.
- Primetals Technologies will provide any upgrades to plant equipment required to support the production of new portfolio elements and their industry certification. The time to market will be shortened thanks to digital solutions such as TPO.

#### Consulting services



[meta.is/consult](https://meta.is/consult)

#### Through-Process Optimization



[meta.is/tpo](https://meta.is/tpo)



### 4. REBAR PRODUCER

Capacity: 300,000 tons per year

Region: Africa

#### Challenges:

- Excessive energy needs
- High electrode consumption
- Issues with plant and scrap logistics

#### Smart solutions:

- A reduction in energy use of the electric arc furnace can be achieved by optimizing the scrap composition and by using the advanced automation solution Melt Expert.
- Melt Expert will also effectively minimize electrode consumption and reduce the related production costs.
- Primetals Technologies can implement a spare-parts management solution that includes the e-catalog m.buy, training sessions for the holistic operation of the plant, and a scrap-yard automation system featuring KPI benchmarking; these measures plus a custom-tailored support package will address the producer's issues.

#### Melt Expert



[meta.is/meltexpert](https://meta.is/meltexpert)

#### m.buy (spare-parts catalog)



[meta.is/mbuy](https://meta.is/mbuy)

# LIVING THE DIGITAL TRANSFORMATION



Agnieszka Teodorczyk, the youngest employee at the Cracow company location, and Mariusz Hyk, the most seasoned one.

## CRACOW IS THE FEATURED COMPANY LOCATION IN THIS ISSUE OF METALS MAGAZINE





Cracow is a place like no other: designated a "European Capital of Culture" and "UNESCO City of Literature," the city attracts some 13 million tourists each year. They come to enjoy Cracow's museums, sights, night life, and typical Polish restaurants. But there is yet another reason to visit Cracow. The company location of Primetals Technologies is a pioneer of digitalization—and develops cutting-edge automation software. Metals Magazine's Dr. Tom Widter reports on Cracow's close ties to the global steel industry.

It is a cold but sunny day in late October of 2020 as I walk toward my rental car—a Ford Focus that will take me from Linz, Austria, to the Polish city of Cracow. Covid-19 is still a force to be reckoned with, and consequently Sixt have thoroughly disinfected the car, as the spotless interior indicates. As I load my luggage into the trunk, adjust the driver's seat, and familiarize myself with the car's navigation system, I wonder if I will encounter any unexpected disruption because of coronavirus. It's not an easy time for business trips: on the one hand, safety must come first, but on the other, business continuity becomes ever more pressing as the world keeps struggling to find its "new normal."

And this new normal will certainly arrive one day. It will likely involve remote work, more elaborate use of video conferencing and live online support, and a further increase in automation and robotics, especially in industrial settings. But it will take time to get there. Meanwhile, my 8-hour trip takes me through the Czech Republic, where a lengthy diversion ahead of Brno sets me back some 30 minutes. Approaching the city of Ostrava, I find myself impressed by the area's beautiful scenery; woods, lit by afternoon sunshine, appearing in all the nuances of green, yellow, and red you can imagine. Then, finally, after almost seven hours of driving, I enter Poland. It happens very suddenly; there is no visible border, just a signpost indicating the new speed limit of 140 km/h. However, the road changes dramati-

cally: it becomes much wider and more modern-looking, and I can't help but be reminded of the "super-sized" highways of North America. The infrastructure in this part of Poland feels modern and fresh.

### EMBRACING CHANGE

Over the last few decades, Poland has made a remarkable political and economic transformation from communism to capitalism. As the staff of Primetals Technologies Poland will later tell me, there are some 10 million people with Polish roots who are now citizens of the United States. The connection between the two countries shows on many levels—the wide roads are just one example. The Cracow area is particularly interesting in that it has become home to a vibrant developer community, especially in the gaming sector. Information technology is a major factor in this city, and Cracow's many universities are making a massive contribution. There is the University of Technology as well as the University of Science and Technology; the latter was formerly known as the "University of Mining and Metallurgy." What better place for a Primetals Technologies location that focuses on promoting digitalization in the metals industry?

Primetals Technologies is situated south of Cracow city center. Upon my arrival, I notice that Covid-19 has led to the implementation of several social distancing, hygiene, and safety measures, including improved security. I ring the doorbell, and a few seconds »



later, Katarzyna Tomanik, the location's office administrator, appears and lets me in. Just like me, she is wearing a face mask—but in spite of the face covering, I can still make out her friendly smile as she welcomes me to the location. I use the hand sanitizer before handing over my jacket; Tomanik then walks me to the office of Dr. Boguslaw Niedbała, the CFO of Primetals Technologies Poland.

### A GLOBAL MINDSET

As we pass through the corridor, I notice a giant wall-mounted world map with many red-and-white stickers in the form of dots. "These dots indicate our project activity," Tomanik says. Europe, Russia, and China seem to dominate, but Egypt and Saudi Arabia are also getting a fair share of the company location's attention. The staff are visibly proud to have such an international footprint. This impression is soon confirmed by Dr. Niedbała, after we've said our hellos. "We do operate globally," he tells me, "which is why travel is so important to us—at least in normal times." 2020 has been an unusual year in many respects; the travel restrictions in several countries have meant that some projects had to be put on the backburner. "If you consider the current situation, we are actually quite busy," says Dr. Niedbała.

There are a couple of factors that have enabled the location to thrive despite the pandemic. "Our goal at Primetals Technologies Poland is to promote an agile environment," Dr. Niedbała explains. "People are allowed not to be boring. You can take on tasks that are not part of your job description. You can reinvent yourself. This is what keeps us fresh." I had been wondering why it was the CFO who introduced me to the company location, and now I understand. The leadership team strives to lead by example, and Dr. Niedbała simply took it upon himself to show me around when the need arose. "When we hire new team members, we make sure they are a cultural fit," he says. "If you want every day to be different from the previous one, you are the right person." This principle, he says, applies to most roles, but there are exceptions: "In some cases, it's also good to have stable specialists who build up expert knowledge over many decades."

### THE POWER OF AGILITY

The word "agile" has many meanings at Primetals Technologies Poland. It not only encapsulates the working culture at large but also describes the way software is developed. Dr. Niedbała invites me to join a Scrum meeting, where a group of programmers is discussing

## TOURING THE CRACOW COMPANY LOCATION



Office administrator Katarzyna Tomanik shows us the large number of projects the company location has proudly completed in many regions of the world.



The recreational area was created to help attract younger talent. It is a cosy place equipped with a billiard and a soccer table, two PlayStations, and a dart board.



CFO Dr. Boguslaw Niedbała, video-conferencing with his team. His tax advisor is based in Warsaw, one team member lives in Rzeszów, and two more work from home.



changes to their code. The software in question is a process-automation system for long-rolling plants called “Process Expert”—it is one of the location’s flagship solutions. New features need to be implemented, and there are some customer requests, as well. The objective of the meeting is to set the right priorities. About two thirds of the team are working from home and everyone in the room is social distancing. Although the meeting is led by the “Scrum Master,” I can sense that there is no strict hierarchy and that everyone is on the same level, irrespective of their position in the company. It is part of the Scrum philosophy to encourage self-organization through an “agile management framework”—which means that it is less important how you achieve your targets, as long as you meet your deadlines and align with your team.

Much of the location’s workforce is made up of millennials; at the time of my visit, the average age of the location’s employees is 35. The atmosphere at the location is vibrant and dynamic. The location houses a recreational area, with a soccer and a billiard table, a dart board, two PlayStation systems, and super-comfy chairs. “When recruiting, we compete with many other companies in the IT sector,” says Dr. Niedbała. “We

found that we had to offer things like this gaming room, free coffee and soft drinks, and flexible hours to attract the best talent in town.” He tells me that new employees react differently to the “panem et circenses” offering: Gen-Xers are genuinely surprised; millennials take these things for granted.

### EXPERTS IN AUTOMATION

The next stop on my tour through the company location is with Szymon Hałat, the melt-shop automation guru at Primetals Technologies Poland. Hałat has been with the company for 17 years, which makes him the ideal person to tell me about the future of Level 1 systems. “Self-diagnostic functions will become more wide-spread,” he says, and assures me that eventually the “smart caster” will arrive in steel plants, with all the power of artificial intelligence under its belt. Just like his colleagues, Hałat embraces the philosophy of agility: “In all my years at the company, I have never done the same thing twice. There is always a new challenge, a new problem to solve. Our customers are working with different systems, different standards, and different targets in terms of the steel grades they want to produce.” What was it that first got him interested in industrial automation? “I realized that when I programmed Level 1 systems »»

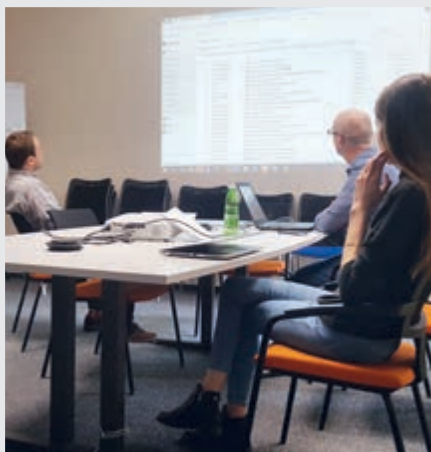

Scrum meetings are used to get all members of a specific software-development team in alignment. New features are just as important as customer requests.



Paweł Hammer is an expert in long-rolling-mill automation. The photo shows him working on code for programmable logic controllers (PLCs, upper right of picture).



How do you design sophisticated electric circuits? Piotr Pelczar would know. The scope of his job includes extensive on-site work to ensure proper implementation.

for steel-plant equipment, what I did on the screen was immediately translated into powerful movement inside the plant—one click on the screen, and the ladle turret started to turn. It was utterly exciting, and there was no room for error.” His eyes light up as he talks about his very special software; I can tell that Hałat is a perfectionist, and for all the right reasons.

I then meet Mateusz Natkaniec and Krzysztof Zątek, both team leaders in Level 2 software development and Level 3 implementation, which implies that they not only oversee process-automation efforts but also the implementation of the production-management system (PMS) offered by Primetals Technologies. Both speak flawless English, especially Natkaniec. “I worked on-site in Pittsburg, Pennsylvania, for two years,” he says. Has the Covid crisis changed people’s minds and hearts in the global steel industry regarding the importance of digitalization? “Definitely, yes,” he says. “Many things that seemed impossible a year ago have now

become a reality.” Krzysztof Zątek shares the same view: “Almost every aspect of our lives has become more digital, and this extends to our daily work with customers in the steel industry.” Both men are conscious that it can be hard to explain the full potential of digitalization in metals production. “Many of our customers want to see working demos of our solutions to get an idea of their real-life impact,” says Natkaniec.

### MAKING A CONNECTION

My next stop is at the labs of Paweł Hammer and Piotr Pelczar, who work in the company location’s basic automation departments. Hammer is busy writing code for programmable logic controllers, or PLCs, which are small, rack-mounted, scalable computers that can withstand the tough environments of industrial settings such as steel plants. Hammer says that most of his software first runs in emulation sandboxes and is thoroughly tested before it is “downloaded” into the actual PLCs. Walking around the lab, I notice Siemens

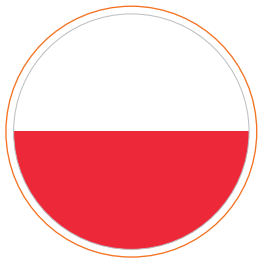

## WHAT MAKES ME PROUD TO BE POLISH ...

**Employees of Primetals Technologies share many passions, such as pioneering new solutions for their customers. But every location also has unique qualities. In this section, we catch a glimpse of what makes Poland so special.**



“ I am proud that Poland has integrated well with the rest of Europe and that we are making our contribution to the future development of the continent.”

**Krzysztof Zątek**

Head of Process Automation, Level 2, Downstream



“ I have witnessed 40 years of change in Poland—from communism to the Solidarity union to the present time. How the Polish people have managed this transition is remarkable.”

**Elżbieta Łuksza**

Delegation Manager, Human Resources



and Allen Bradley PLCs. “We aim to support multiple platforms. It enables us to work with a greater number of steel producers, who often have legacy equipment installed,” Hammer explains.

Piotr Pelczar has an equally interesting job. His work desk looks impressive with no fewer than three large-sized screens, which display something that looks like the blueprint of an electric circuit. “These circuits are my life,” says Pelczar. Or at least a big part of it. I learn that there are European and American ways of drawing these designs, and that a major evolution has taken place: copper cables were replaced by Ethernet cables many years ago; these days, Pelczar relies on the Profinet standard for significantly greater reliability of data transmission. When he’s not drafting new designs, Pelczar goes on site to help contractors with the installation. This usually takes place during, not after, the fundamental construction phase of a project and can take many months. “I used to spend about 80 percent

of my time on site,” says Pelczar. He now has a family and chose to cut his time abroad to 30 percent. “That is still a lot,” I suggest. “Sure, but I like it,” Pelczar replies enthusiastically.

### FROM POLAND TO THE WORLD

Before I sit down with the leadership team to discuss my impressions, I have a chat with the administrative staff. Elżbieta Łuksza is the location’s delegation manager. She knows all about international travel, and it is not hard to guess that Covid-19 has made her job even more, well, interesting. While speaking with her, I finally understand something that I’ve been noticing during my time in Poland, but was unable to put into words. Where does the Polish entrepreneurial spirit come from? What are the roots of this unique mix of optimism and realism? “I was 18 years old,” Łuksza explains, “when communism ended. I still remember the empty shops and the desolate buildings. We went from communism to Solidarity to the here and now, »



“ Nationality is something given to you by chance. I am proud of my achievements and those of my team, but this feeling does not necessarily extend to the wider nation of Poland.”

**Mateusz Natkaniec**  
Head of Process Automation, Level 2, Level 3, and PMS



“ I am proud of the Polish people. We are well-educated and hard-working, and we have an entrepreneurial quality. Polish start-ups have won many competitions. I also adore our nature—from the forests to the Baltic sea.”

**Ewa Klamka**  
Head of Accounting, Financial Services



“ I think our nation was united under complicated circumstances. Despite our checkered history, the Polish heart has remained unbroken. The Polish people are quick to adapt to changes and capable of making the most of limited resources.”

**Szymon Hałat**  
Deputy Head of Melt-Shop Automation



## CREATING FUTURE-PROOF SOFTWARE SOLUTIONS

Szymon Franczyk is one of Primetals Technologies Poland's drivers of innovation. He is a team leader in Level 2 automation.

### Is there any innovation that you are particularly proud of?

**Szymon Franczyk:** That would be our Process Expert long-rolling mill automation solution. We wanted to design something that was going to be future-proof and easy to adapt for new customers. Process Expert is browser-based and has a modular structure, so that any modification of the code only involves one dedicated part of the software.

### Are there any "tricks" you use to promote creativity and inventiveness?

**Franczyk:** I try to surround myself with people who volunteer new ideas or make innovative contributions by asking the right questions. They can be a true eye-opener. Also, our Scrum methodology is helpful in generating new ideas because you work your way backward from customer expectations; how you achieve these results is up to you, your team, and your collective creativity.

### Is creativity something you are born with, or something acquired by training?

**Franczyk:** I have an 8-year old son, and from watching him I have come to believe that creativity is something you are born with. However, to nurture creativity, you need to make certain experiences and be given the right opportunities. You depend on the world you grow up in to give you the information you need to process your thoughts and ideas.

and I am so proud of what we achieved as a nation." It is part of the Polish mentality not to be burdened by the country's checkered history; rather than wrestle with it, the Poles embrace their heritage and make the most of it, with considerable bravery, confidence, and determination. They focus on the future, on the possibilities, and on how to make a difference in this world. And for the world of metals production, I can't help but feel that Primetals Technologies Poland is doing a lot.

My concluding meeting with CEO Czupryna and CFO Niedbała allows me to put my observations into context. The location was founded in 1992, and just like Poland itself, underwent several transformations. In recent years, the team successfully entered new markets: while collaborations with other Primetals Technologies entities remain crucial, the location now also executes its own projects. This development was an important contributor to overall growth—and in recognition of the location's business strategy and success, Primetals Technologies Poland was awarded the "Gazela Biznesu" by Polish business daily "Puls Biznesu." Over time, the location has accumulated more than 400 references all around the world and has grown to a head count of 95. "It is our ambition to think globally," says Piotr Czupryna. "What I appreciate about the steel industry is that it is much like a worldwide family, where you are rewarded for networking and for sharing your experiences with others."

As I leave Cracow, I begin to think about how best to tell the story of the company location, how best to convey what the staff and the management team care about most. It strikes me that I learn so much about leadership on these trips—and about the extent to which mentalities and mindsets translate into everyday work practices. I remember something Dr. Niedbała told me in the recreational area—the room with the billiard table and the PlayStations. "As leaders, we have to balance 'doing the right things'—making strategic moves—with 'doing things right'—ensuring smooth business operations," he said. "We must do both to enable everyone at Primetals Technologies Poland to stay agile, to collaborate, and to be open to the change that may become necessary to pioneer the future of the company." As I accelerate to 140 km/h, the voice on the radio tells me that the Czech Republic has just gone into lockdown. Would Austria follow suit? Would I get home okay? In times like these, "doing things right" may not always be easy. But it matters that we try. And that we stay agile.



#### Covid-19 disclaimer:

We followed strict hygiene and social distancing protocols in the creation of the article.

[Learn more at meta.is/mmcovid](https://meta.is/mmcovid)



# A DAY IN THE LIFE OF ANGELIKA SKUPIEN-JANUSZ



**ANGELIKA SKUPIEN-JANUSZ**  
HR and payroll specialist

As part of the series “Visiting the Company Locations of Primetals Technologies,” we sit down with one employee of the respective location—with the aim of illustrating what a regular work day is like for them.



# EXPERIENCING THE CITY OF CRACOW AND THE SPIRIT OF POLAND



## THE UNITY TOWER ...

... is Cracow's second-highest building and located close to the University of Economics. It is 102.5 meters tall and was originally intended to become the regional office of Poland's Main Technical Organization. Economic constraints, political unrest, and legal disputes led to the extraordinary construction time of 40 years.



## ST. MARY'S CATHEDRAL ...

... in its current form was re-erected in the 14th century by two brothers, according to folklore. When the younger brother found that his tower was shorter, he became envious and murdered his older sibling with a knife. The murder weapon is still on display on the main square of Cracow.



## TADEUSZ SENDZIMIRA STEELWORKS ...

... is Poland's second-largest steel plant. It started operation on July 22, 1954 in a new eastern district of Cracow called "Nowa Huta." During communist rule, the plant went by the name "Vladimir Lenin Steelworks." The plant produced almost seven million tons of steel in the 1970s and now belongs to ArcelorMittal.

## POPE JOHN PAUL II ...

... became archbishop of Cracow in 1964 before he was made Pope in 1978. He had a deep connection to the city—and even supported the Cracovia soccer club. During his time in Cracow—and later visits—, John Paul II tried to reach out to the locals and had conversations with believers from his balcony.



# IMAGINATION WITHOUT LIMITS

Piotr Czupryna is CEO of Primetals Technologies Poland, which comprises the company locations in Cracow and Rzeszów, both in southern Poland. Czupryna has been with Primetals Technologies (and predecessor companies) for 22 years. In his role of CEO, he has doubled down on the entrepreneurial spirit of the Cracow company location, extended its portfolio, and worked toward a truly global footprint. With 400 references worldwide, Czupryna and his team continue to push the limits.



## When did you join Primetals Technologies?

**Piotr Czupryna:** It was April 1998, when I was still at university. One of my professors told me about a company in Cracow that was developing a software solution for the steel industry and who were looking for young people, willing to travel, with knowledge of English, and good software skills. I knew a lot of people at the time who were joining new, fast-growing software companies in Cracow, and they were earning well, so seeing it as a good opportunity I decided to apply.

## So you were looking for more than just a desk job?

**Czupryna:** The opportunity to travel, to visit new places, and to meet people from all over the world, was extremely tempting—despite the picture I had in my head of steel plants being dirty, dusty, and noisy places. Somehow I found the steel plant to be more attractive than the sterile environment of a programmer's office. After I joined the team my first project involved a continuous casting line in China. In November of 1998, I found myself on site in Hangzhou in Zhenjiang Province, China, a city described by Marco Polo as heaven on earth. I found it wonderful.

## How would you describe the wider agenda of the Cracow company location?

**Czupryna:** From the very beginning, the Cracow organization had two main goals: to service the market in Poland for the parent company, and to provide high-quality engineering resources in the area of software engineering for global large-scale projects. I added two more dimensions—we started to offer our own portfolio elements to steel producers worldwide, and we became a hub for higher-level software development within Primetals Technologies.

## How would you describe the current situation in the Polish steel industry?

**Czupryna:** Like everywhere else in the world, steel intensity is falling—perhaps not as quickly as in Western Europe—, and as a consequence of environmental considerations and increasing labor costs, production has become more expensive. Our customers here in Poland are struggling to balance cost-effective production against keeping their carbon footprint to a minimum, while also supplying increasingly sophisticated products. The installed capacity of their plants is higher than their production figures.

## What's the outlook for the global steel business?

**Czupryna:** The market as it currently exists will begin to shrink as steel production drops on account of falling steel intensity. Having said that, there will be a new market driven mainly by decarbonization, digitalization, the development and manufacture of advanced steel grades, and the optimization of the production process. Other factors include the transformation of global supply chains, governmental initiatives and regulations, as well as new green-production technologies.

## Are there any technologies beyond metals production that intrigue you?

**Czupryna:** I'm fascinated by information technology, because it has had such a massive and far-reaching impact. I'm expecting to see some innovative developments in thermonuclear fusion, as well as the growth of hydrogen in the automotive and industrial sectors.

## In your view, what are the limits to innovation?

**Czupryna:** There are none. If something is physically possible, it will be realized one day. ●



# A PIONEER FOR EVERY OCCASION

At Primetals Technologies, we know that no two metals producers are alike. Our customers come to us with unique challenges, and we strive to provide them with equally unique solutions. Over several decades of customer-oriented innovation, we have pioneered many groundbreaking technologies that have shaped the way that metals are produced today.

Innovation is not something that just happens. It is the result of hard work, creativity, and inspiration. The best innovations are made in close collaboration with equal partners—and this is truly the case with many of the solutions of Primetals Technologies. Metals producers come to us aiming to resolve specific issues, which we investigate and for which we find the right solutions. These solutions stem from the trust producers place in us, and from the mutual determination to succeed.

Our extensive R&D work also greatly contributes to our large portfolio of metals-production technologies, which remains unmatched in the industry. Our tireless researchers always focus on the future and on what it may hold. Even more importantly, we do what we can to actively shape the future—by pioneering innovations that will transform the world of metals. At Primetals Technologies, we want to be catalysts for change. We reach for new heights. We are pioneers at heart.







# BETTER INNOVATION WITH GLOBAL TEAMS

With some 7,000 employees in 26 countries, Primetals Technologies is no small enterprise. There are 300 R&D specialists relentlessly chasing their next breakthrough, and 60 key experts aiming to make the most of their deep knowledge about metals production. Add to that the 55 R&D partnerships that Primetals Technologies maintains with companies all over the world, plus the 25 arrangements with universities and scientific institutions—it is hard to grasp the sheer amount of brainpower united under the umbrella of Primetals Technologies.

Yoichi Matsui is the pioneer that has set out to tackle this seemingly impossible mission. He runs an initiative that brings together teams and individuals from different cultures and various technological fields to achieve something groundbreaking. His goal, says Matsui, is to create innovations that will help to increase performance in steel mills even beyond today's standards. Under the code name "MEWS," his projects are rooted in the technological knowledge of his contributors. The idea is that Primetals Technologies can unleash its full potential whenever a diverse set of competencies is channeled in one common direction. Throughout his career as a project manager, Matsui has always been open-minded. He aims to "push the world forward to make it a better place, thanks to the steel made with our products." Cars, ships, trains, electronics, and buildings all use steel and contribute to our societies' welfare. "Improving peoples' lives is what inspires me to pioneer new things," Matsui says.



#### YOICHI MATSUI ...

... is pioneering groundbreaking projects that bring together the best of the best of Primetals Technologies' researchers and key experts from all around the world.

#### GLOBAL INNOVATION ...

... is no small feat. Bridging the gaps between different cultures requires understanding, openness, commitment, and passion.





# SMARTER SOFTWARE

## FOR THE STRAND

One of the most important aspects of continuous casting is secondary cooling: only the right cooling strategy, cooling intensity, and water distribution ensure that the resulting slabs, blooms, and billets solidify with pristine, homogeneous surfaces and the desired atomic structure. But in order to determine the correct parameters in secondary cooling, metallurgists need to know as much as possible about the thermodynamic properties of the cast steel—properties like enthalpy, density, and conductivity. Traditionally, the information that was available for specific steel grades was limited to one set of parameters for the liquid phase, one for the solidified phase, and one for the state in between the two, the so-called "mushy" phase.

Dr. Susanne Hahn changed all this—and enabled metallurgists to know more than ever before about the temperature-dependent thermal properties of the steel composition. Her innovation, DynaPhase, even works in real time, performing its calculations as the steel is being cast. DynaPhase helps to determine the correct temperature for each point of the strand at any given time. It lays the groundwork for an accurate prediction of the final point of strand solidification and for the correct application of the appropriate amount of soft reduction. Asked about the biggest challenge in the development of DynaPhase, Dr. Hahn says that "numerical stability and the speed at which the software had to run" were the hardest targets to achieve. But she got there—almost in real time.



### DR. SUSANNE HAHN ...

... is a physicist and joined Primetals Technologies to develop a software tool that calculates the material properties of solidifying steel.

### DYNAPHASE ...

... provides metallurgists with detailed, temperature-dependent material parameters of the steel in real time, as it is being cast.

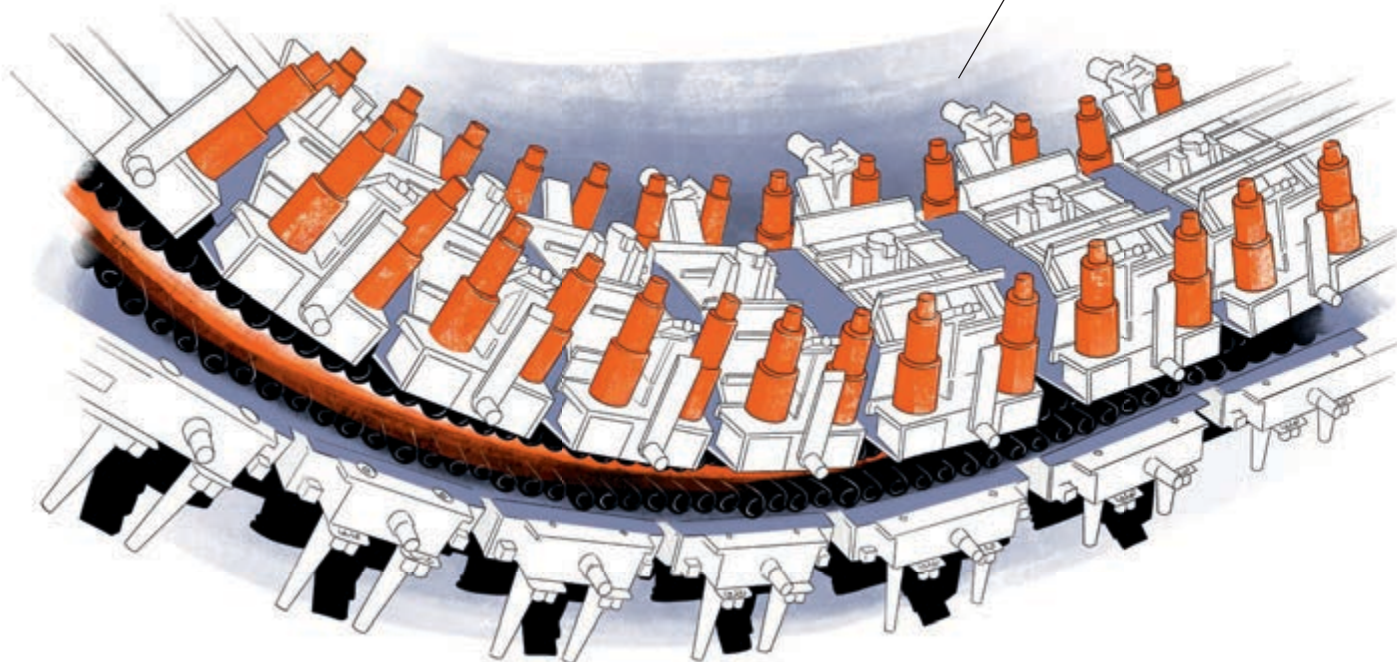

# STANDARDIZING AUTOMATION

Throughout the metals industry, there are many different kinds of rolling mills in active use, each with its own unique characteristics and range of applications. For a long time, this heterogeneity was reflected in the automation solutions that powered the mills: there was a multitude of platforms, and every platform was associated with certain types of cold-rolling mills. Maintaining this broad range of platforms and corresponding automation solutions was a challenge, and occasionally it was almost inevitable that certain innovations based on one platform would not make it to all the others. Understandably, with developments in cold-mill automation leading to an increasingly diverse landscape, the need arose to create one solution that would be compatible with all mill types and that could easily be kept up-to-date.

Martin Schönherr was instrumental in creating a new automation solution universal enough to replace the numerous existing systems. "We wanted to arrive at a solution that would be innovative at the core, yet very simple to maintain," he says. "The target was for it to enable every possible implementation—and work with any cold mill, from the simplest to the most complex." During the development of the novel automation solution under the project name "CM2020," Schönherr and his team had to transition to a new platform on which the scalable software would run. "This aspect really was a challenge," Schönherr confirms. "But we did succeed and were able to pioneer a new level of standardization."



## MARTIN SCHÖNHERR ...

... successfully created one powerful yet scalable automation solution for cold-rolling mills that could replace a multitude of divergent older architectures.

## COLD-MILL AUTOMATION ...

... has historically used a variety of platforms. Standardization has made maintenance much easier and has improved scalability.

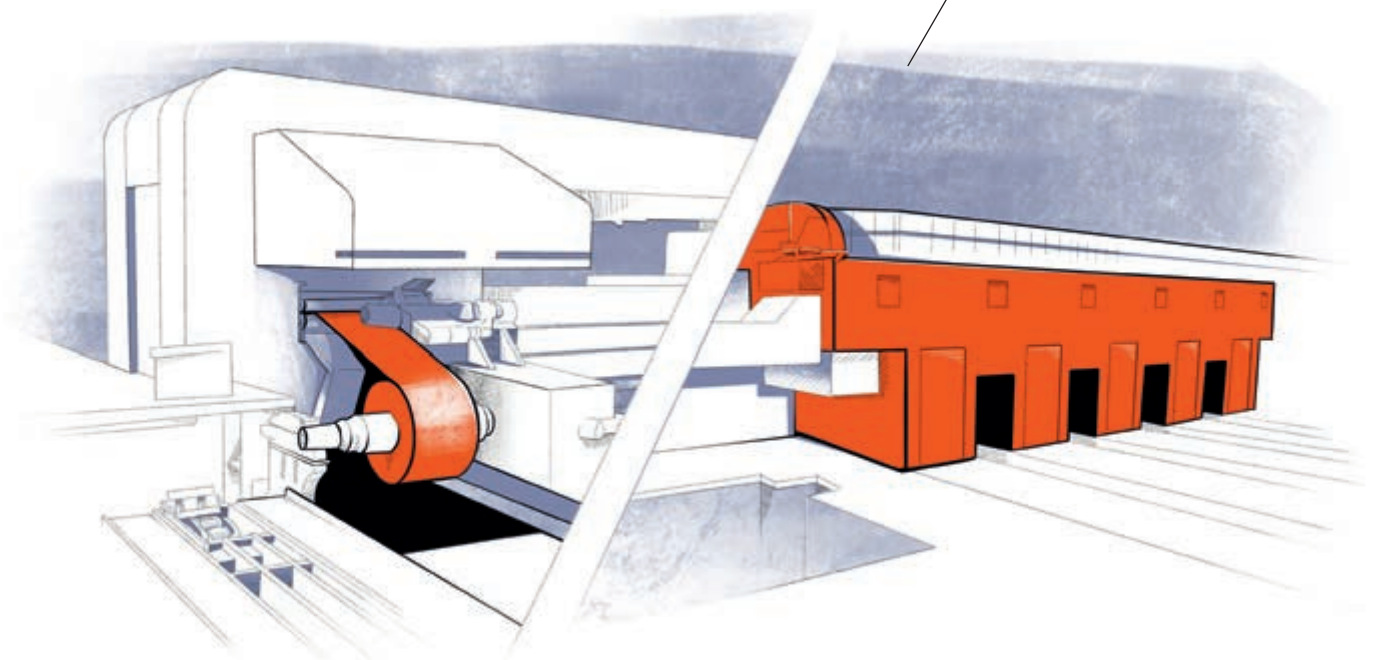

# MORE CONVERTER FOR EVERYONE

For many decades, Primetals Technologies, including its predecessor companies VAI and Siemens VAI, has been renowned for its converter solutions. The company pioneered the Linz-Donawitz (LD) converter, which led to the widespread use of the basic oxygen furnace in steelmaking. With LD converter technology, new and higher-quality steel grades became possible.

When Stefan Dimitrov joined VAI in 1991, LD converter-based (BOF-based) steelmaking was limited in terms of how much scrap could be used as raw material: 25 percent was regarded as the highest possible proportion, with hot metal accounting for the rest. In the late 90s, however, China rapidly industrialized, and as a result, raw material prices soared. Dimitrov was tasked with finding a way to lower the cost of steel production by modifying converter technology to use more scrap—and by reducing energy requirements. "I found several methods to solve this problem," he says. "The combination of scrap preheating, increased post-combustion, allothermal converter operation by means of directly inputting carbon, and improved bath mixing enabled us to realize scrap percentages as high as 50 percent." So successful was Dimitrov that he was soon asked to further extend the converter's range of applications so that it could produce stainless and special steels as well as special hot metal and slag products. A pioneer of both the analog and digital worlds, Dimitrov is also the brains behind an advanced Level 2 system for the converter.



#### STEFAN DIMITROV ...

... extended the range of applications for the BOF and enabled it to use more scrap. He also contributed his metallurgical expertise to a novel Level 2 system.

#### THE LD CONVERTER ...

... was pioneered in Austria in 1952 and eventually led to the worldwide success of the integrated steel-production route.

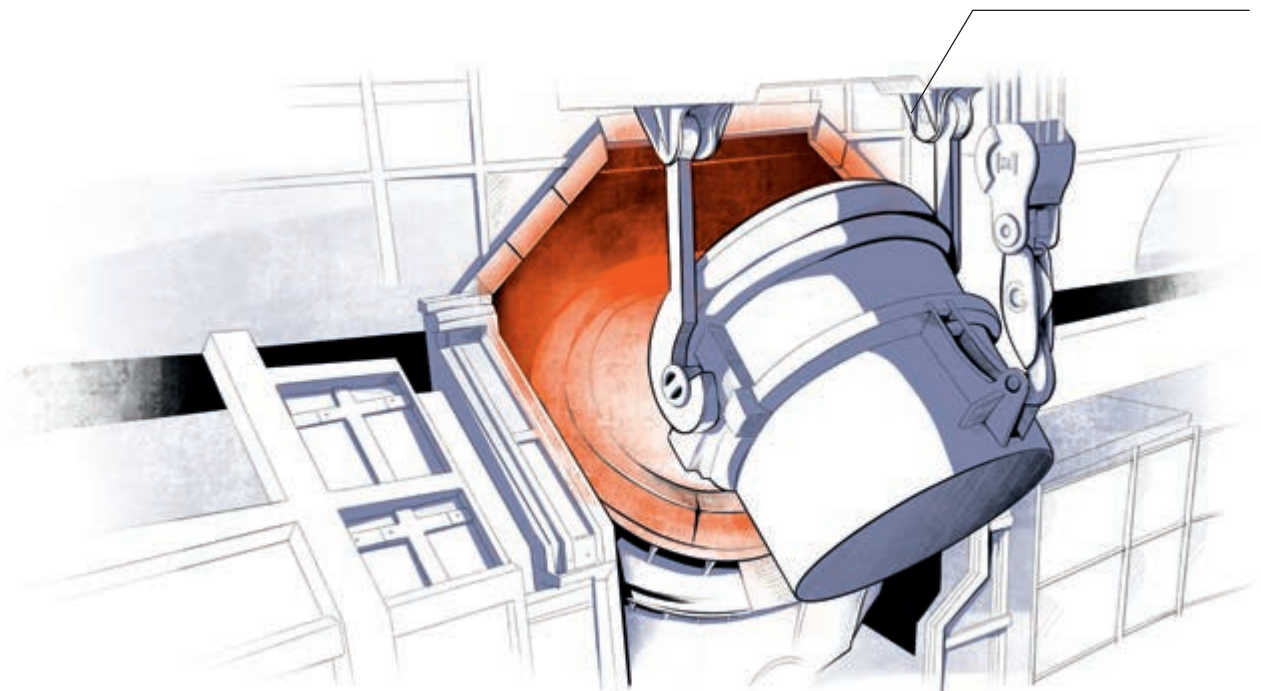



# THE GROUNDWORK

## FOR DIGITALIZATION

A smart production-management system (PMS) can make a big difference in the day-to-day operations of a steel producer: It ensures optimum plant and equipment utilization thanks to its planning and scheduling capabilities. It also helps to reduce order-turnaround times, to scale down end-product inventories, and to improve order-delivery times. A good PMS furthermore contributes to higher product quality and lower costs—in terms of production, energy consumption, and logistics. While Primetals Technologies, in 2016, established a successful partnership with German-based PSI and now deploys the company's PSImetals PMS solution, significant R&D work was done leading up to that development. This work arguably shaped the industry's perspective on production management in general and on the need for manufacturing-execution systems in particular.

Louis Deaulmerie was one of the early pioneers of PMS solutions. He made his first endeavors into the world of advanced software solutions over two decades ago as part of the "Industrial IT" team. In 2009, he started to look into the requirements of a highly configurable, reliable PMS that would comply with the industry standards and norms of the time. Today, he works to advance the status quo of the integration of the PMS into other Industry 4.0 tools. "Pioneering keeps your mind alert and forces you to think 'out of the box,' says Deaulmerie. "Exploring new frontiers, new technologies, has always been part of my life, and that won't change."



### LOUIS DEAULMERIE ...

... made forays into the nascent field of production-management software earlier than most, ensuring that standards would be supported.

### PMS ...

... stands for "production-management system." It is one of the most important tools in the digitalization of steel production.



# TURNING CAPEX INTO OPEX

Traditionally, whenever a steel producer wanted to install a new automation system, they knew they had to plan for the associated capital expenditure (CAPEX). Depending on the size of investment, any decision to make the purchase had to be approved by upper management, which could result in delays or in the decision being overturned. OPEX-based license models, however, are free of these downsides. They have already become the new norm in the world of computer software, where companies such as SAP and Microsoft have been instrumental in facilitating change. In the steel industry, subscription licenses are still a new phenomenon, but producers are waking up to the fact that OPEX items are easier to buy and maintain than their more traditional CAPEX counterparts.

Bojan Jozic has developed a new subscription license model that enables steel producers to benefit from all the advantages of an OPEX purchase while still receiving a full-fledged, state-of-the-art solution. The first product sold in the form of a subscription was a Level 2 system for a continuous casting machine. The customer was so confident in the model that they signed a 12-year contract. Included in the agreement is a package of software updates and services. "It truly is a 'worry-free' package for the producer," says Jozic about the subscription. "Making the transition from CAPEX to OPEX arrangements was a great journey—and required me to think out of the box, like any pioneer should."



#### BOJAN JOZIC ...

... has done pioneering work in the field of sales: he aligned the needs of today's steel producers with the new trend toward subscription-based purchases.

#### SUBSCRIPTION LICENSES ...

... have been a widespread phenomenon in the world of computer software for a while now and are starting to gain traction in the realm of steel production.

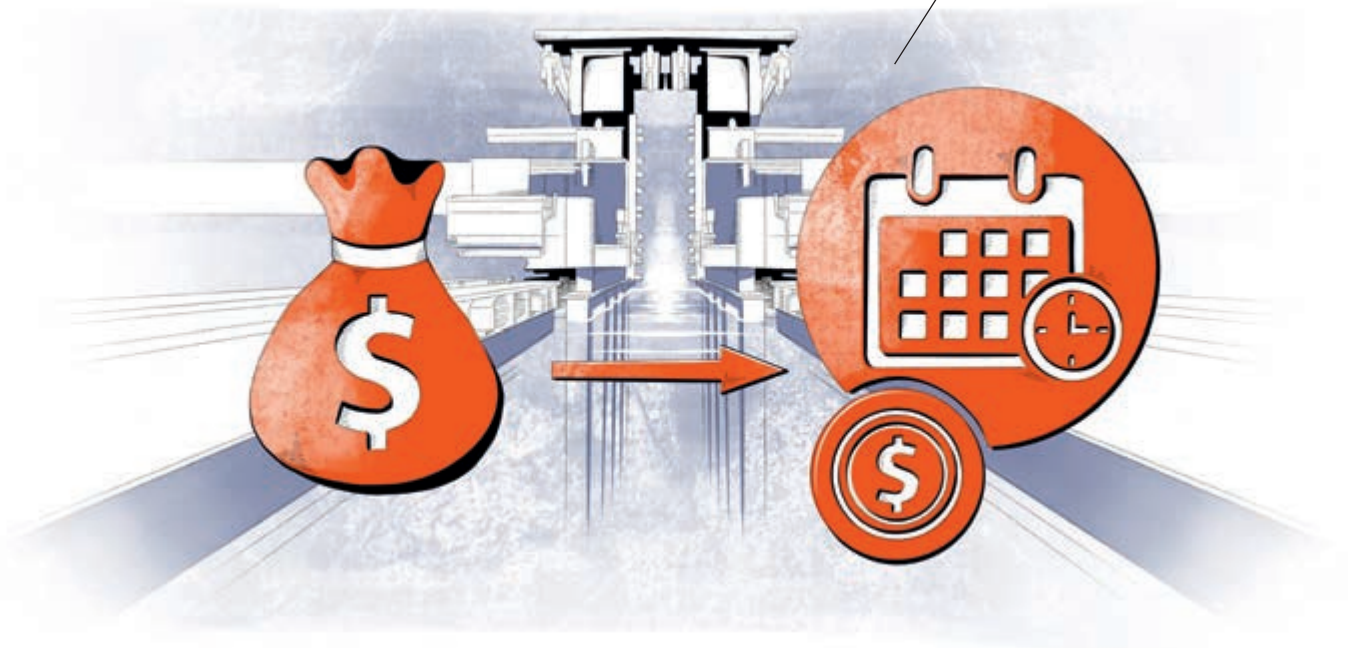



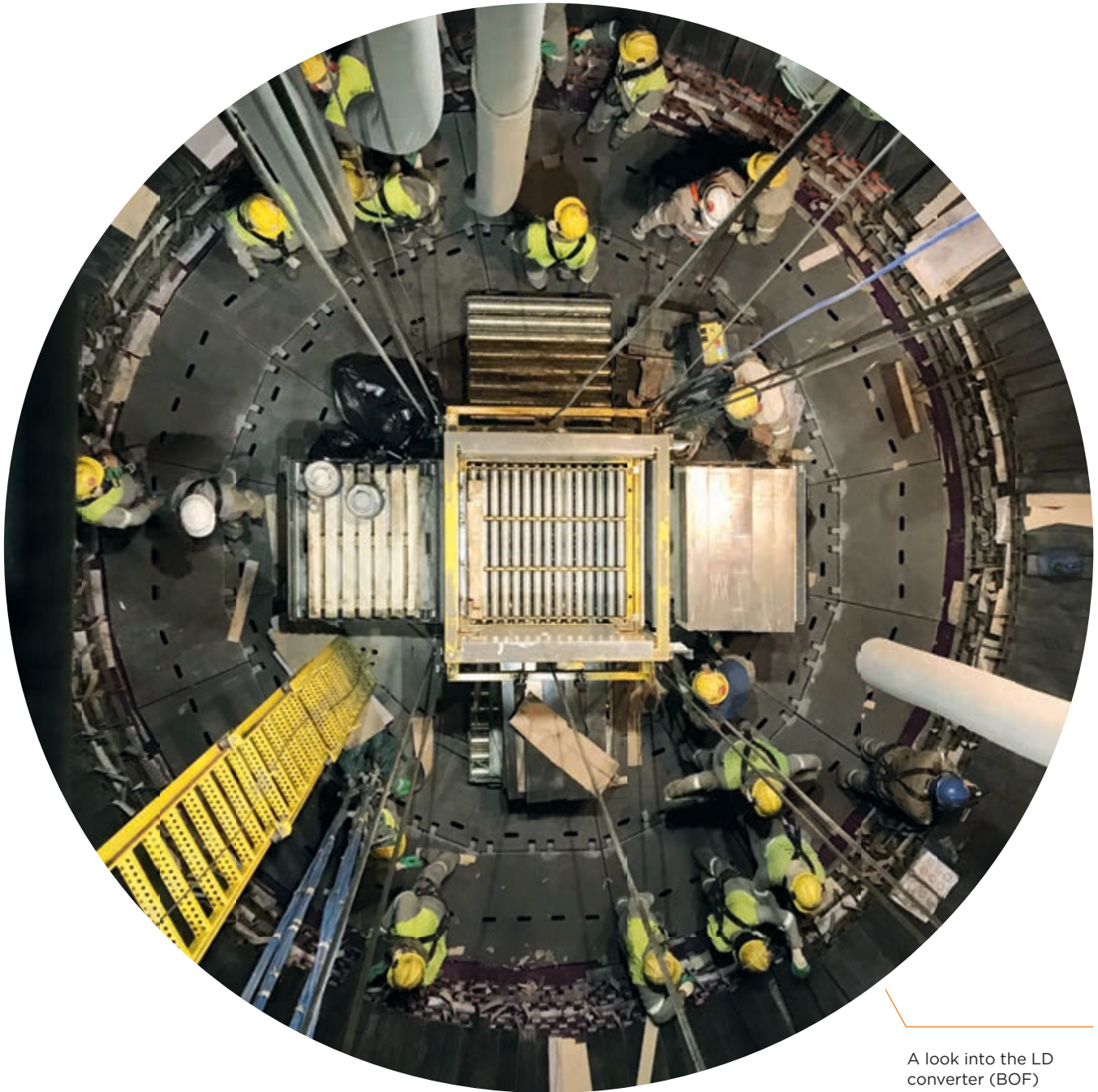

A look into the LD converter (BOF) reveals Ternium's new relining solution.

# BOF RELINING MADE FASTER

Primetals Technologies developed and implemented a new LD converter (BOF) relining solution at Ternium's Santa Cruz plant—making relining safer, simpler, and much faster.



## **Ternium asked Primetals Technologies to carry out an extensive study to evaluate potential new relining solutions, and to develop a new relining machine geared toward Ternium's requirements.**

Ternium Brazil is a leading manufacturer of steel products and prides itself on the use of the most advanced technologies available. In 2010, Ternium opened a steelmaking plant in Santa Cruz in the municipality of Rio de Janeiro with an annual capacity of five million tons. The melt shop—one of the largest in South America—is equipped with two 330-ton LD converters (BOFs). It produces slabs, which are sent to Ternium's rolling mills in South America for further processing.

Ternium realized that whenever one of its two converters was in relining mode, the other converter was forced to cope with a much higher workload (more than 34 heats per day), and there was no time for regular maintenance, such as slag splashing. Consequently, the refractory lifetime was significantly reduced. Ternium therefore decided it was necessary to cushion the impact on the refractory while also increasing the productivity of the converter operation, which ultimately meant reducing the relining time and—given the limitations of the existing relining machine—implementing a new and improved relining process.

There was a second reason why Ternium wanted to change their relining practices. Until 2019, Ternium was using a relining machine and a refractory concept where the relining process was carried out through the removeable bottom of the converters. Once relining of the vessel shell side walls was complete, the newly relined converter bottom was inserted. This approach generates a sensitive area between the side wall and the bottom refractory, the so-called bottom joint, which has to be filled with ramming mass and closed with great care in order to keep the liquid steel from

breaking out. Ternium's aim was to increase operational safety by moving from a bottom relining to a top relining approach.

Ternium therefore asked Primetals Technologies to carry out an extensive study to evaluate potential new relining solutions, and—based on the study's results—to develop a new relining machine geared toward Ternium's specific requirements. Much to Ternium's interest, the relining study revealed further disadvantages to bottom relining, such as limited accessibility to the area below the converter during maintenance procedures—this area was fully occupied by the relining machine. Furthermore, at the end of the relining process it was necessary to bring in the workers from the top, through the converter mouth, using a sub-standard cage to finish the bottom joint and massively compromising safety as a result.

### **A CUSTOM-MADE SOLUTION**

Relining machines are highly customized solutions and the stakeholders involved in relining are incredibly diverse, which meant that Ternium's requirements for the project were extremely challenging. The company's operations team was focused on reducing the relining time and increasing productivity as well operational safety, while the goal of the maintenance team was to reduce the maintenance effort and increase employee safety. The engineering team was intent on making sure that Ternium implemented the best available, most reliable solution, while those on the front line of the relining project—the workers themselves—were concerned with improving their working environment, level of safety, and the ergonomics of the relining procedure. »

Faced with this complex set of challenges, Ternium and Primetals Technologies chose a two-prong approach that, in a first step, involved a comprehensive study to assess the current relining procedure and to come up with possible improvements as well as a bespoke concept for a new relining machine, followed by actual project implementation in a second step.

The aim of the study was to identify bottlenecks and limitations in the current relining procedure and also to develop three concepts for a new relining machine based on Ternium's specific requirements. Experts from both companies teamed up and used the opportunity of a regular relining shutdown to carry out a detailed on-site analysis of the existing relining procedure (brick logistics, personnel, time, lifting capacity) and an inspection of installation space.

Based on the results and after detailed discussions with Primetals Technologies, Ternium decided to change the relining procedure from bottom to top relining, which would fulfil the requirements to both decrease relining time and improve operational safety. Ternium's previous relining procedure was revealed to

have serious limitations in terms of lifting capacity of the pallet elevator. It also precluded any parallel maintenance work below the converter.

### DOUBLING CAPACITY

The new relining machine features a double-pallet elevator with reduced cycle time, which has doubled capacity and reduced relining time by more than a day. The new solution also requires less maintenance, while a comprehensive safety concept covers both the staff and operational aspects. There is still room for greater efficiency, since the manual work inside the converter could be executed in an even more streamlined manner, and Ternium is continually monitoring and optimizing this area.

The relining machine features a working platform suspended by four working ropes and four safety ropes, a platform winch with holding brake on the rope drum, and a load pin for monitoring slack rope, uneven load distribution, and overload on each rope-deflection wheel. An identical load pin and monitoring solution are implemented for the elevator winch. The machine's advanced automation system includes a safety PLC



### FUNCTIONAL TESTS

Because the relining machine featured a completely novel design, it was thoroughly tested in Austria prior to shipping.

### FINAL INSPECTION

Ternium collaborated on the engineering and manufacturing of the machine and sent staff to Austria for the final inspection.

## Ternium decided to change the relining procedure from bottom to top relining to improve relining speed and increase overall safety.

and a wireless remote control for safe operation from the working platform inside the vessel.

The load capacity of the double pallet elevator is up to 4.5 tons, while lifting speed is 20 meters per minute. The achieved cycle time of the elevator, including feeding the lower pallet, moving to upper pallet position,

feeding the upper pallet, moving down to the working platform, unloading, and moving back up, is less than seven minutes. The maximum lifting speed of the working platform when transporting staff is two meters per minute. Another highlight of the relining machine is the electrically driven feeding system, which was realized as a roller table and which makes loading the refractory brick pallets onto the platform easy and convenient. It is possible to load and unload pallets from different directions, and even to unload them from both sides.

Unlike bottom relining, top relining does not produce a bottom gap in the refractory, which means there is no danger of break-out. A separate telescopic ladder with fall protection allows workers to access the working platform safely, and it is no longer necessary for them to be transported in a cage. In addition, the relining machine is fully roofed, protecting workers from any skulls falling from the dedusting duct.

### ALL MADE IN AUSTRIA

The new relining machine was wholly developed by Primetals Technologies based on the results of the study carried out at Ternium, and the solution fully »



### COLD COMMISSIONING AND TRAINING

The machine was pre-assembled outside of the steel plant to ensure a smooth startup and to train the Ternium staff.

### STARTUP AND FIRST RELINING

On October 29, 2019, the relining machine project was completed, and the first relining was executed ahead of schedule.



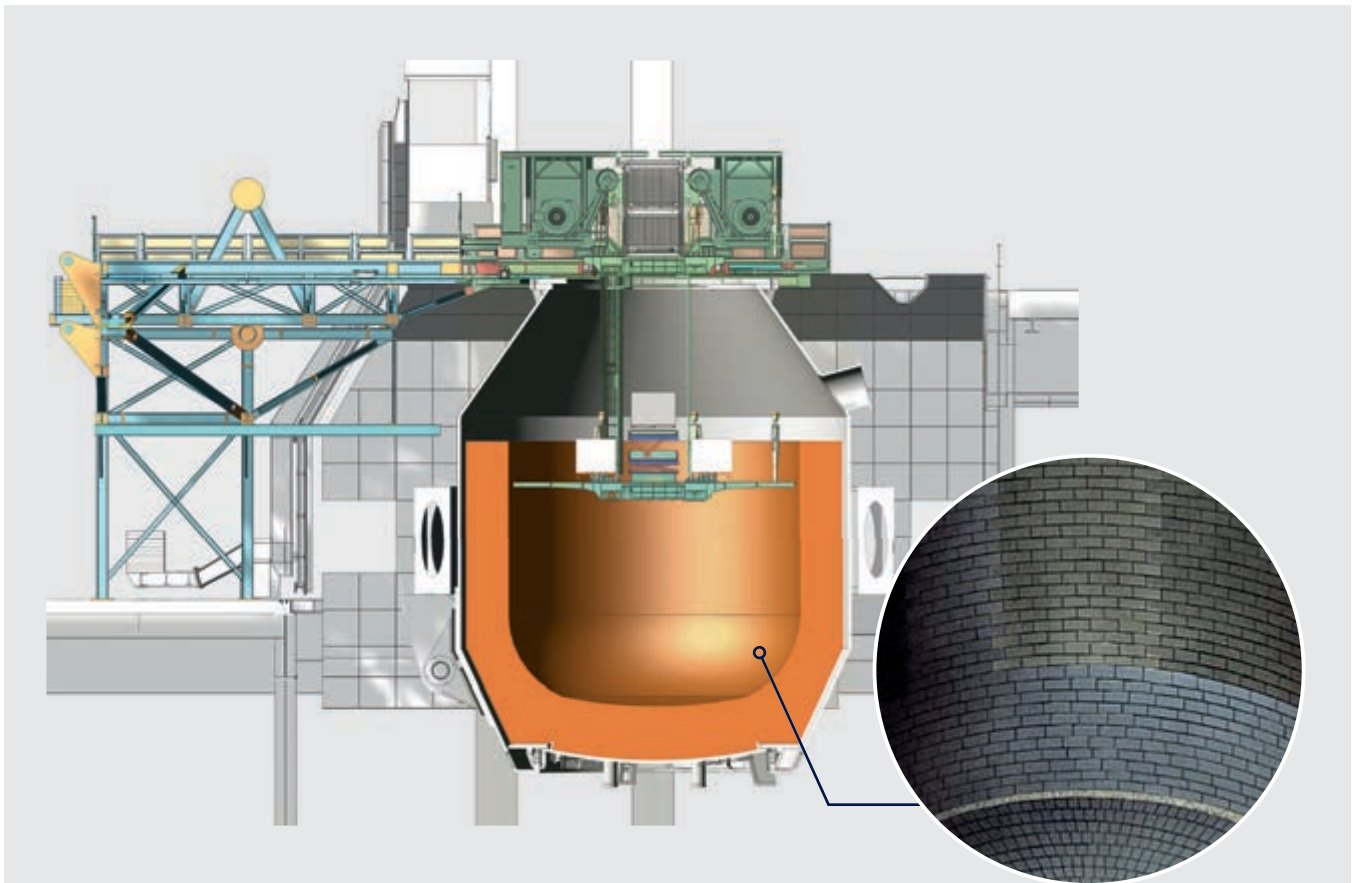

## WHAT IS CONVERTER RELINING?

Just like all metallurgical vessels, Linz-Donawitz (LD) converters—also known as basic oxygen furnaces (BOFs)—require a refractory lining inside the steel shell in order to cope with liquid steel temperatures as high as 1,700°C. The refractory lining is designed to accommodate the complete LD (BOF) steelmaking process—from the charging of scrap and hot metal, to the blowing process with carbon oxidation and slag formation, and ultimately the tapping of steel and slag.

With a large 330-ton converter, as is the case at Ternium Brazil, the lining has a total weight of around 800 tons and consists of more than 100 layers of bricks. There are more than 17,000 bricks in total, each of which weighs up to 40 kg. Refractory bricks are made of carbon or resin-bonded magnesium oxide and the quality varies for the different fields of application such as the slag zone or the scrap-impact area.

Generally, the refractory lining consists of two elements: the safety lining, close to the vessel shell, and the wear lining, which is in direct contact with the liquid steel. The wear lining can be clustered into several regions, depending on its

function: the bottom lining with the bottom-stirring elements, the transition area to the lower cone, the barrel section, and the upper cone.

The wear lining is a consumable product and must be replaced when the minimum thickness is reached. The typical lifetime of a converter lining—referred to as the converter campaign—is approximately 4,000 heats. Depending on the operation of the converter, the number of heats can be lower because of higher liquid melt temperatures or aggressive slag, or as high as 10,000 with regular lining maintenance and gunning in place.

Given that most converters have permanently installed vessels, the relining must be done directly inside the installed equipment, rather than at a dedicated “lining station” that would be used if the converters were exchangeable. Generally, there are two approaches to converter relining: for converters with a fixed installed bottom, the relining needs to be carried out from the top, through the converter mouth. For converter vessels with a removable bottom, the relining can be carried out either through the top or bottom.

“Fully automated relining is still not feasible today, but we can make workers’ lives a lot easier with advanced digital tools.”

complies with the latest European as well as Brazilian standards. The entire process greatly benefited from the excellent relationship between Ternium and Primetals Technologies and the combined expertise of the two companies. The engineering and development work was done in Austria in close collaboration with European suppliers, and regular design reviews were carried out together with the Ternium project team.

Once manufacturing was complete, the core equipment was pre-assembled and a thorough functional test was carried out in Linz, Austria, in the presence of Ternium’s project team. Once the equipment was given the green light, it was shipped to Brazil for installation. Prior to startup, the new solution was extensively tested and the relevant maintenance and operational staff at Ternium underwent comprehensive training.

The first relining procedure with the new machine took place at the end of October 2019, when the solution went into operation ahead of schedule. All performance parameters were met and Ternium was happy to sign the Final Acceptance Certificate (FAC). To underline the long-term, trust-based partnership between the two companies, staff from the Brazil and Austria locations of Primetals Technologies and the Ternium team will continue to collaborate closely in order to further refine the relining procedure and to resolve any technical support cases that may occur in the future. ●

**Bernhard Voraberger**, Project Manager & Head of Converter Steelmaking Technology, Primetals Technologies Austria

**William Correa**, Project Manager, Ternium Brazil

**Leonardo Demuner**, Steel Plant Manager, Ternium Brazil



## TAKING A BIG STEP TOWARD FULLY AUTOMATED RELINING

In this interview, Bernhard Voraberger reveals the digital future of LD converter (BOF) relining and discusses new collaborations.

### What’s next in converter relining?

**Bernhard Voraberger:** We are developing new technologies that make the relining process less labor-intensive and even safer. Fully automated relining is still not feasible today, but we can make workers’ lives easier with advanced digital tools.

### Are you already offering such digital relining tools to steel producers?

**Voraberger:** Yes. Our most recent, digitally enhanced approach toward converter-relining involves a robot, a brick-identification system, and a smart set-pattern generator. The task of the set-pattern generator is to create a digital data set that describes the refractory lining inside the converter—based on the current converter geometry, the available brick formats, and brick qualities according to the lining plan from the refractory supplier. The handling and positioning of the bricks is then done automatically.

### What has been the reaction from industry partners to this novel solution?

**Voraberger:** Refractory suppliers have shown great interest in our automated relining solutions, and supplier RHI Magnesita has signed a cooperation agreement with us, which will promote even closer cooperation. Together, we will develop even more sophisticated automated relining solutions. Interest from steel producers has also been significant.

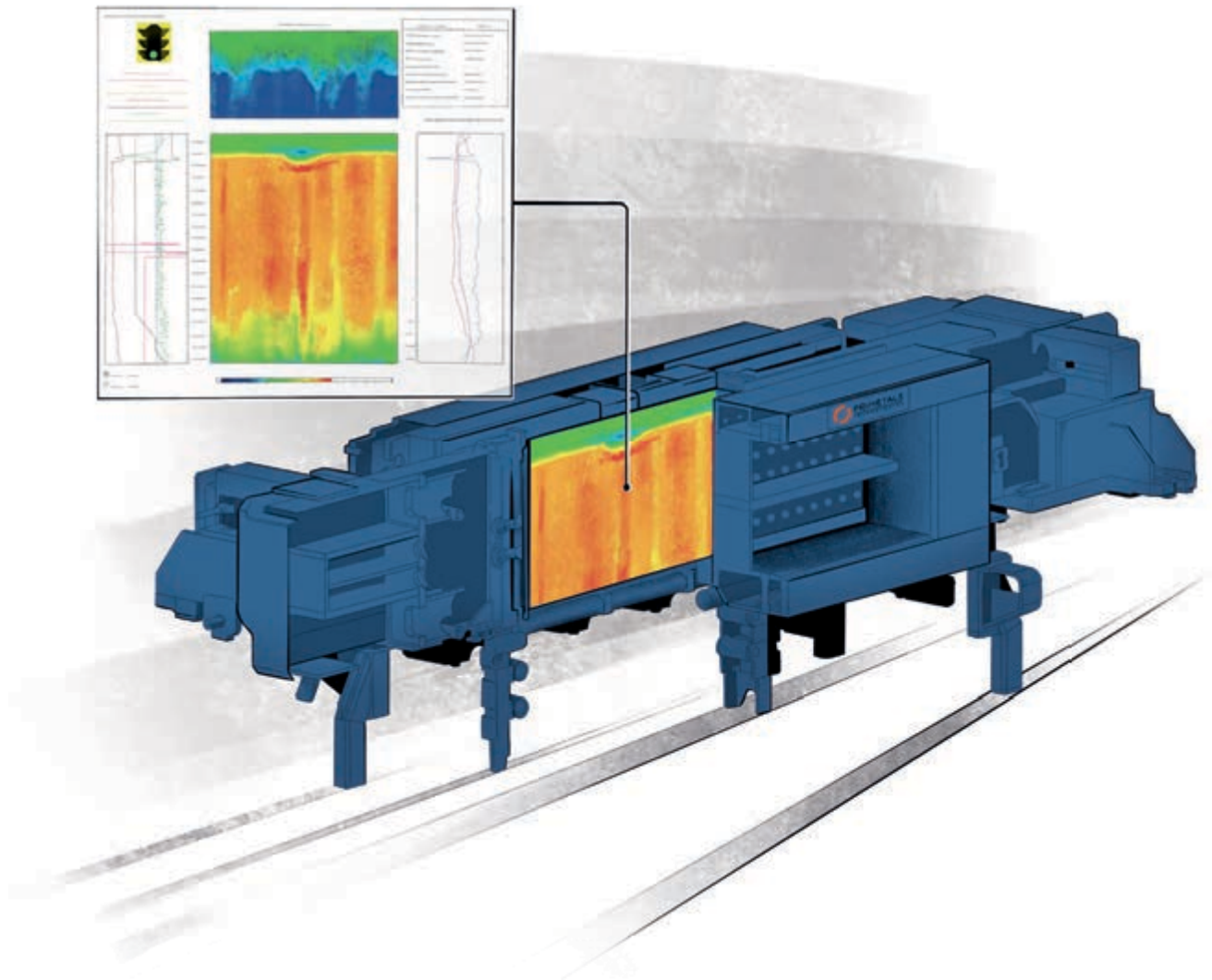

# MAKING THE CASTER MOLD **TRANSPARENT**

**MOLD EXPERT, THE INNOVATIVE STICKER-DETECTION SYSTEM FROM PRIMETALS TECHNOLOGIES, HAS NOW BEEN INSTALLED OVER 300 TIMES IN MELT SHOPS ALL AROUND THE WORLD.**

In the 20 years since its inception, Mold Expert has not been standing still. The solution has supported countless melt-shop operators around the world in casting perfect slabs, blooms, and other intermediate steel products by preventing breakouts. The new version, Mold Expert Fiber, uses fiber Bragg gratings for an even clearer picture of what goes on inside the mold.



**“ The data from the first casting showed us that the auto-adaptive algorithms were working as they should, and from the second casting onward, automatic casting speed reduction was turned on.”**

**Dr. Oliver Lang**

Innovation Manager, Mechatronic Products

The development of Mold Expert began in 1998, when Dr. Oliver Lang was asked to investigate the sticker-detection systems that existed at the time—with the aim of developing a proprietary system for VAI, the Linz-based predecessor company of Primetals Technologies. There were two main aspects to consider: on the one hand the hardware required to obtain the essential temperature measurements from the mold, and on the other hand the software algorithms to detect stickers, with the human-machine interface visualizing and interpreting the temperatures.

At the time, thermocouples were primarily based on constantan rods that were welded onto a copper plate. The welding could only be carried out by an expert to ensure a strong joint. Another major disadvantage of using copper plates as the second element of the thermo-pair was that this design choice resulted in the diagnostic signals being very susceptible to interference. Dr. Lang and his colleagues therefore collaborated with a thermocouple manufacturer and came up with their own thermocouple design, which differed significantly from that of competitors, owing to its extremely fast response to temperature changes and interference immunity.

As a result of the faster temperature detection, “stickers”—incidents in which part of the nascent strand shell becomes stuck to the mold—could also be detected far more quickly and thus more reliably. Another benefit of the new design was that basically anyone could mount the new thermocouples: you simply had to insert them into the right slot and to turn them slightly clockwise, and they would click into place. An integrated spring made sure they were



## A PERFECT PARTNER FOR THROUGH-PROCESS OPTIMIZATION

Mold Expert is also a crucial source of production data for Primetals Technologies' very own Through-Process Optimization (TPO) solution, where all process-relevant data can be stored and evaluated—from the ironmaking stage all the way to the final coiling. TPO is one of the flagship digitalization solutions of Primetals Technologies. It is capable of tracking all parameters relevant for the production process and of storing that information for every coil produced. The aim is to have thorough knowledge of the current and the theoretically achievable end-product quality at the respective production line. TPO introduces a level of transparency previously unknown in steel production, thereby making product and process optimization more simple and straightforward. Thanks to its sophisticated rules-based system, operator knowledge as well as expertise from Primetals Technologies can be mirrored and preserved for automatic application.



### FURTHER READING

To learn more about TPO, scan the QR code or point your web browser to the link below.

[meta.is/tpo](https://meta.is/tpo)

pressed against the copper plate with constant force. By using K-type thermocouples (chromel-alumel thermocouple pairing) and twisted, shielded thermocouple cables, the team was able to reduce interferences even further.

On the software-development side, the team benefited from the very close relationship between steel producer voestalpine and VAI, which enabled the VAI team to examine how stickers form and spread. Based on this knowledge three algorithms were developed for the recognition of stickers. They were programmed to work universally on all continuous casting plants worldwide. Importantly, they made auto-adaptive parameters a core principle of the innovation that was to become Mold Expert. These parameters automatically set themselves to the right values according to the casting behavior of the new plant without the need for prior configuration, and their functionality would today certainly be labeled as exhibiting artificial intelligence.

### THE FIRST INSTALLATION

Things became really exciting for the Mold Expert team in 2000, when the first implementation became operational at IPSCO Steel in Alabama, U.S.A., now SSAB Alabama. Although the algorithms of Mold Expert had been thoroughly tested in the context of the partnership with voestalpine, the question was how they would behave on a completely different system and in conjunction with the new thermocouple design.

Because Mold Expert was yet unproven, its ability to automatically reduce casting speed remained switched

off. Instead, Dr. Lang sat in the electrical room with his eyes firmly glued to the temperature curves, all the while in radio contact with a metallurgist directly at the casting platform, who was authorized to manually initiate casting speed reduction. “The data from the first casting showed us that the auto-adaptive algorithms were working as they should, and from the second casting onward, automatic casting speed reduction was turned on,” Dr. Lang says, proudly. Since this initial success, SSAB Alabama and Primetals Technologies have remained close partners and have developed countless new features for Mold Expert. SSAB Alabama was also the first customer to sign a service contract for the solution, which ensured that they would always be using the latest version.

One of the anecdotes Dr. Lang has to tell about his collaboration with SSAB Alabama relates to the time difference between the U.S.A. and Austria: “With Mold Expert, early on, we introduced the fundamental philosophy that the tasks of the programmer and the commissioning engineer would be kept separate,” Dr. Lang says. “This worked great thanks to the time difference and the resulting differences in sleep-wake cycles.”

As the commissioning engineer, it was his job to carry out the installation, test the system, and identify bugs: “I was able to give SSAB Alabama’s system my undivided attention. The programmer could stay at home in Austria and devote himself entirely to implementing additional features according to customer requests. The result was that while I slept, the programmer was improving the code.” »

## 20 YEARS OF MOLD EXPERT IMPLEMENTATIONS



The team behind the project that involved the first-ever implementation of Mold Expert



The Mold Expert HMI, neatly embedded into an operator station casting-platform pulpit



Programming work on a Mold Expert implementation, as it used to be executed in 2001

## THE EVOLUTION OF MOLD EXPERT'S HUMAN-MACHINE INTERFACE

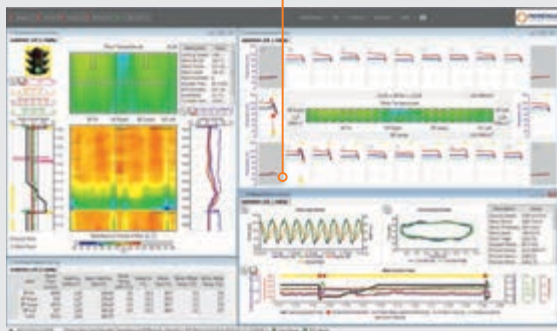
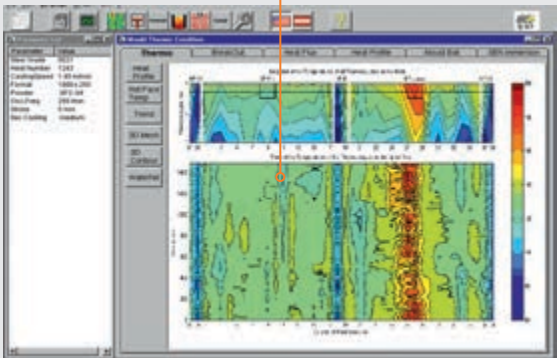

Mold Expert was first premiered at IPSCO in early 2001. The human-machine interface (HMI) at the time was basic yet already highly functional.

More recent implementations show how much Mold Expert has matured. The HMI has become even more powerful as Mold Expert has been extended with specialized modules.



A close-up look at a caster mold, the place where the Mold Expert hardware does its magic

Two Primetals Technologies employees after a recent successful installation of Mold Expert





## WHAT OUR CUSTOMERS ARE SAYING ABOUT **MOLD EXPERT**



**“ We cast a large variety of difficult steel grades. Mold Expert is one of our key instruments to reliably cast such grades without problems.”**

**Dr. Franz Ramstorfer**  
Continuous Casting Consultant,  
Ternium Brazil



**“ We have been using Mold Expert Fiber for five years now. It helps us to increase productivity. We use it in combination with AI algorithms to detect inconsistencies.”**

**Jürgen Reiter**  
R&D Specialist,  
voestalpine Stahl Donawitz GmbH

### MOST RECENT REFERENCES

As of early 2021, Mold Expert has been implemented over 300 times in steel plants worldwide, making it the #1 mold-monitoring system in the metals industry. These are some of Mold Expert's most recent references.

- JSW Steel, Dolvi Works (CSP)
- HBIS Laoting
- voestalpine Stahl (on caster CC8, as a replacement for a third-party system)
- Novolipetsk Steel (as an upgrade)
- Rizhao Steel (5-line Arvedi ESP plant)

### A GROWING PLATFORM

When developing Mold Expert, the team always wanted the solution to be more than purely an early warning system to prevent breakouts. That is why, right at the beginning, the add-on module Friction Expert was developed, which calculates the friction between strand and mold. Friction is a very important parameter that informs the metallurgist about whether the casting powder is functioning correctly. Mold Expert had also been growing as a project within Primetals Technologies, which brought additional manpower in the form of Martin Schuster, who took the lead in pushing the development of Mold Expert forward and taking it to the global market.

When the Mold Expert team trained plant operators, they were often asked what ranges should be targeted—for example, the ranges within which the fric-

tional forces or the heat flows in the mold ought to stay. The Mold Expert team could not provide a one-size-fits-all answer, given that these variables depend on many parameters. But it was also evident that the steel grade and the casting powder were of special relevance.

The question ultimately prompted the team to develop the patented Process Expert module, which continuously analyzes the casting process and, based on the vast amount of data stored in its database, suggests ranges within which the friction and heat flow values should be moving. “This algorithm employs artificial intelligence to automatically register new steel grades and casting powders, and continually refines itself as the product-development process at the plant progresses,” says Martin Schuster.

### ANNIVERSARIES AND OUTLOOK

In 2020, Primetals Technologies celebrated 20 years of Mold Expert—and the 5th anniversary of using a fiber-optic temperature-measuring system in Mold Expert’s hardware design. The move to fiber optics was made due to the advantages of fiber Bragg gratings for temperature measurement in the mold. This approach allows for many more temperature measuring points to be monitored than with thermocouples, leading to a much more high-resolution temperature profile of the mold. Thanks to the richness of this data, it is possible to calculate the precise shape of the mold level, and to even draw conclusions about the flow conditions within the mold.

“In the future, fiber Bragg gratings will be used even more extensively—on the one hand to control electromagnetic brakes and stirrers in such a way as to ensure the optimal flow of steel in the mold, and on the other hand as a replacement for the thermocouples used in earlier Mold Expert implementations,” Martin Schuster prophesizes. “The initial investment needed for such an advanced system is somewhat higher, but down the line maintenance costs are lower. And in the case of tubular molds, the use of fiber-optic cables is already easier and more cost-effective because of the specific design of these molds and the way they are cooled.”

Over time, Mold Expert has arguably developed into a pioneering innovation platform, and further developments in the pipeline point to the solution’s bright and interesting future. Smart assistants—such as Peritectic Expert, which uses Mold Expert data to inform the operator whether peritectic steel is being cast—will increasingly be supporting the casting process and will contribute to even more comprehensive and advanced automation in the continuous casting plant. ●

**Dr. Oliver Lang**, Innovation Manager, Mechatronic Products

**Martin Schuster**, Product Manager, Mold Expert

**Nicole Oberschmidleitner**, Head of Mechatronic Products

(All with Primetals Technologies Austria)



## A NEW DIMENSION OF CONTINUOUS CASTING

Martin Schuster is the product manager behind Mold Expert. He dedicates his time and energy to making continuous casting more reliable.

### How has Mold Expert changed the world of continuous casting?

**Martin Schuster:** Mold Expert lets you inspect what goes on inside the mold and helps you identify any inconsistencies in the casting process. The result is greater reliability. Some 20 years ago, the much-feared breakouts were still relatively commonplace. But thanks to Mold Expert, you can now run a continuous casting machine for many years without a breakout ever occurring.

### What was the most important factor in the development of Mold Expert?

**Schuster:** We have been continually refining the algorithms used in Mold Expert. The goal has always been to enable it to detect a wide range of phenomena. We extended its core functionality with a number of Expert Modules. Another important aspect was that we provided our customers with after-sales support and that we helped them analyze the data they generated with Mold Expert.

### What’s next for Mold Expert?

**Schuster:** The new version, Mold Expert Fiber, will define the next 20 years of continuous casting. The new technological paradigm of using fiber Bragg gratings improves the resolution of temperature points in the mold by a factor of 100. It adds a whole new dimension, and my team and I are very proud of it.



**FIG. 1:** Cold-rolling mills, such as the one shown in this picture, often have untapped potential for higher productivity and greater reduction rates.

# THE FULL POTENTIAL OF **COLD-ROLLING MILLS**

**THE COLD-ROLLING EXPERTS OF PRIMETALS TECHNOLOGIES KNOW HOW TO MAXIMIZE THE POTENTIAL OF A COLD-ROLLING MILL, ENABLING THE INTRODUCTION OF NEW PRODUCTS AT ZERO RISK.**





New products inevitably require a swift response to market demands as well as short-term changes to the operation of rolling mills in order to cope with shifting landscapes. And success depends on both targeted investments with a short ROI, as well as on short downtimes. Primetals Technologies works closely with steel producers to develop sophisticated strategies that enable them to react quickly to market demand, to gradually expand their product range, and to increase productivity and product quality.

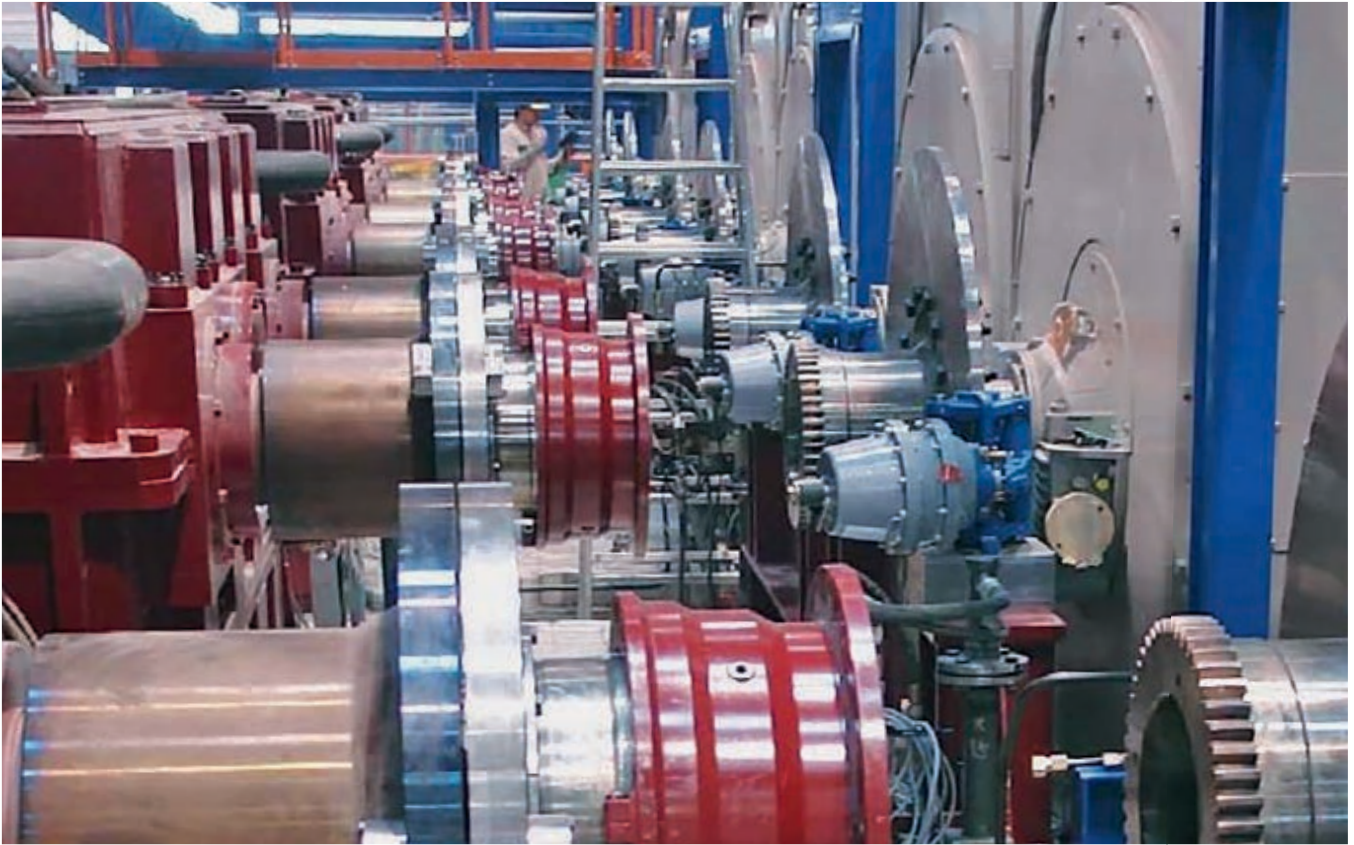

**FIG. 2:** Drives and gear boxes of rolling-mill stands.

Even when business is good, operators of cold-rolling mills are confronted with new challenges all the time. Primarily because their own customers have a relentless appetite for new, increasingly modern products or new materials. This means that steel producers are forced to react quickly to market dynamics and make the necessary product-portfolio adjustments as swiftly as possible. Meanwhile the quickly shifting landscape often pushes existing plants to their very limits—or compromises productivity and quality. The key to remaining competitive is modernization.

### **EFFICIENT MODERNIZATION**

Which begs the question, to what extent should a plant actually be modernized? In practical terms, how much investment is required for such an approach to be cost-effective? At the end of the day, capital expenditure needs to ensure a profitable result and a quick return on investment. Even if general modernization might seem the right way to go initially, more often than not it is counterproductive because it involves lengthy downtimes and, more significantly, is extremely expensive. Primetals Technologies takes a very specific,

customer-driven approach to finding the right solution. Competent experts work closely with producers to help them make precisely the right investments in their plants, step by step and always with one eye on the future.

Digitalization should enable different parts of a plant to integrate seamlessly with one another, thereby accelerating workflows and optimizing production. Primetals Technologies' optimized approach first involves analyzing the existing situation at the plant. Any weaknesses, as well as areas where autonomous systems would be beneficial, are identified. The analysis also focuses on expected delivery times and necessary downtimes—and on how long it will take before production is up and running again. In addition, boundary limitations are made with regards to objective, installed base, and plant-related and structural limitations.

### **FINDING OPPORTUNITIES**

Primetals Technologies uses fact-based analyses performed by two specialized online tools, which allow operators of cold-rolling mills to be more flexible in how they plan for the future: The "Process Model" is continually being refined and is capable of calculating



	width	hN	hX	red	vExit original	increase required	vExit required	vExit new	increase possible
Product	[mm]	[mm]	[mm]	[%]	[m/min]	[%]	[m/min]	[m/min]	[%]
A_EQ_min	900	3.2	0.96	70	1152	3%	1187		REV*
A_EQ_max	1400	3.2	0.96	70	936	3%	964	1120	20%
A_NQ_min	900	3.2	0.96	70	1145	3%	1179		REV*
A_NQ_max	1400	3.2	0.96	70	892	3%	919	1120	26%
B_EQ_min	900	3.2	0.64	80	1347	7%	1441		REV*
B_EQ_max	1500	3.2	0.64	80	990	7%	1059	1321	33%
B_NQ_min	900	3.2	0.64	80	1342	7%	1436		REV*
B_NQ_max	1500	3.2	0.64	80	900	7%	963	1319	47%
C_EQ_min	1600	3.2	1.28	60	846	7%	905		MAXENS*
C_EQ_max	1700	3.2	1.28	60	796	7%	852	900	13%
C_NQ_min	1600	3.2	1.28	60	815	7%	872	900	10%
C_NQ_max	1700	3.2	1.28	60	767	7%	821	900	17%
D_EQ_min	1500	3.2	0.96	70	868	7%	929	1140	31%
D_EQ_max	1800	3.2	0.96	70	737	7%	789	1107	50%
D_NQ_min	1500	3.2	0.96	70	826	7%	884	1140	38%
D_NQ_max	1800	3.2	0.96	70	690	7%	738	977	42%
E_EQ_min	1600	3.2	0.64	80	919	20%	1103	1305	42%
E_EQ_max	1800	3.2	0.64	80	810	20%	972	1133	40%
E_NQ_min	1600	3.2	0.64	80	837	20%	1004	1221	46%
E_NQ_max	1800	3.2	0.64	80	738	20%	886	1078	46%

**FIG. 3:** The Process Model used by Primetals Technologies can simulate the pass schedules of a certain product group and reveal the mill's full potential.

\* REV, MAXENS: physical limits of equipment reached

**Based on the results of the analysis, Primetals Technologies works closely with the steel producer to find the best modernization strategy.**

the rolling mill pass schedules (see Figure 3). The "Utilization Model" is based on the Process Model and uses its results to achieve maximum capacity utilization and consequently maximum throughput. These two online tools also make possible the creation of targeted process simulations for entire plants—a capability that can be used to highlight production and to plan around bottlenecks, which can be eliminated by taking very specific measures.

#### **BUILDING A STRATEGY**

Based on the results of the analysis, Primetals Technologies works closely with the customer to determine the best strategy. This includes addressing any weaknesses in the plant and identifying untapped production potential, as well as strategies for tapping this potential. Ultimately, however, it is important to set targeted priorities: parts of the plant that are initially excluded from investment should still be included in the catalog of measures so that the rolling mill operator can modernize them at a later or more convenient date without significant effort or expense.

**Josef Hofbauer**, Sales Director and Consultant, Electrics and Automation, Primetals Technologies Germany.



# CASE STUDY: HIGHER VOLUME, GREATER REDUCTION

A steel producer from Asia wanted to increase the production volume and reduction performance for certain product groups. Primetals Technologies carried out an analysis and formulated a strategy within 12 months. The plant was put into a planned downtime of only two weeks; afterwards, productivity was restored as quickly as possible. The new product range, the required reduction, and the new technical environment were immediately available, thanks to the pre-parameterized Process and Utilization Models.

## ANALYZING THE PLANT

Primetals Technologies took a very systematic approach. First a rough analysis of the mechanical, electrical, and automation systems was carried out, based on the following questions:

- Which stands are capable of achieving the targeted reduction rates?
- Are there any parts of the production chain that have untapped potential?
- How can this potential be tapped?
- How does automation need to be modified?

Existing pass schedules, as well as load and reduction distribution at the plant, were also analyzed; as were maintenance and service routines.

## FROM WEAK POINTS TO STRENGTHS

Based on the analysis, those parts of the plant with the greatest influence on increasing throughput and total reduction rate could be identified: in this case it was the bridle rolls at the entry side of the tandem cold mill, the motors, and the stand drives. A number of previously unknown or overlooked weaknesses were also identified and included in the overall analysis. The analysis revealed, among other things, that the existing pass schedules from the process model were not aligned with the production setup at the time. The weaknesses were prioritized and, wherever appropriate in terms of the desired objective, incorporated into the catalog of measures.

This customer also benefited from the use of the tried-and-tested online system developed by Primetals Technologies, the Process Model in combination with the Utilization Model. The Process Model was virtualized with all plant-specific data; this allowed the anticipated results to be verified in advance using current data of the production process. The findings were incorporated into the modernization plan and served as the basis for the system test and subse-

quent customer training. Based on this simulation, Primetals Technologies, in collaboration with the cold-rolling mill operator, was able to dynamically push to the limits and thus calibrate the plant for specific production segments while tapping the full potential.

The online system effectively visualized the targeted optimization potential of the customer's plant (see Figure 4). Both production and productivity witnessed an increase for all product groups. The plant resumed operation without any loss in production. Declared benefits such as an increase in reduction and mill speed were already evident within the first week of production. The customer was fully satisfied: by optimizing mill power, it was possible to significantly increase reduction and mill speed (Figure 5). Furthermore, the mill is now flexibly able to turn out products and sizes that were previously considered unviable, thereby ensuring long-term stability in planning. ●

## DEFINING THE MEASURES

According to the analysis of the customer's current situation, the following measures were necessary:

- Installation of new drive trains (transformers, converters, motors, and drives) for two stands.
- Lifting of the checked and verified reserves of the drive trains on the remaining aggregates (e.g. stands, motors)
- Examination of technical and technological threshold values (e.g. rolling force, torque, power)
- Definition of parameters for new components to avoid structural measures
- Optimization of cooling at transformers
- Securing reserves of existing equipment and new components by expanding process models and plant automation
- Simulation of new reduction distribution
- Definition of new plant limits

### PERFORMANCE INCREASE AFTER MILL MODERNIZATION

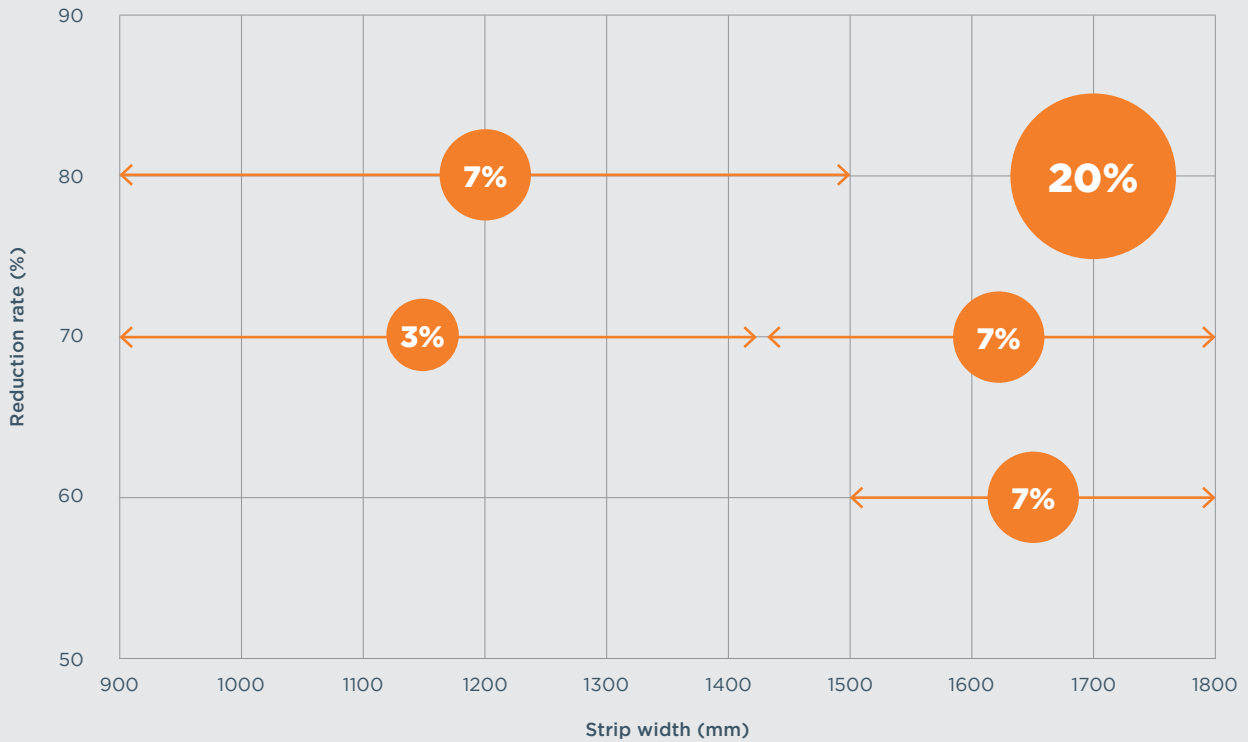

**FIG. 4:** Mission accomplished—for products of certain sizes, it was possible to increase production volume by 3, 7, or even 20 percent, thanks to increased reduction rates. The circles indicate the extent to which production volume was increased at specific strip widths and reduction rates, which are reflected by the X and Y axes, respectively.

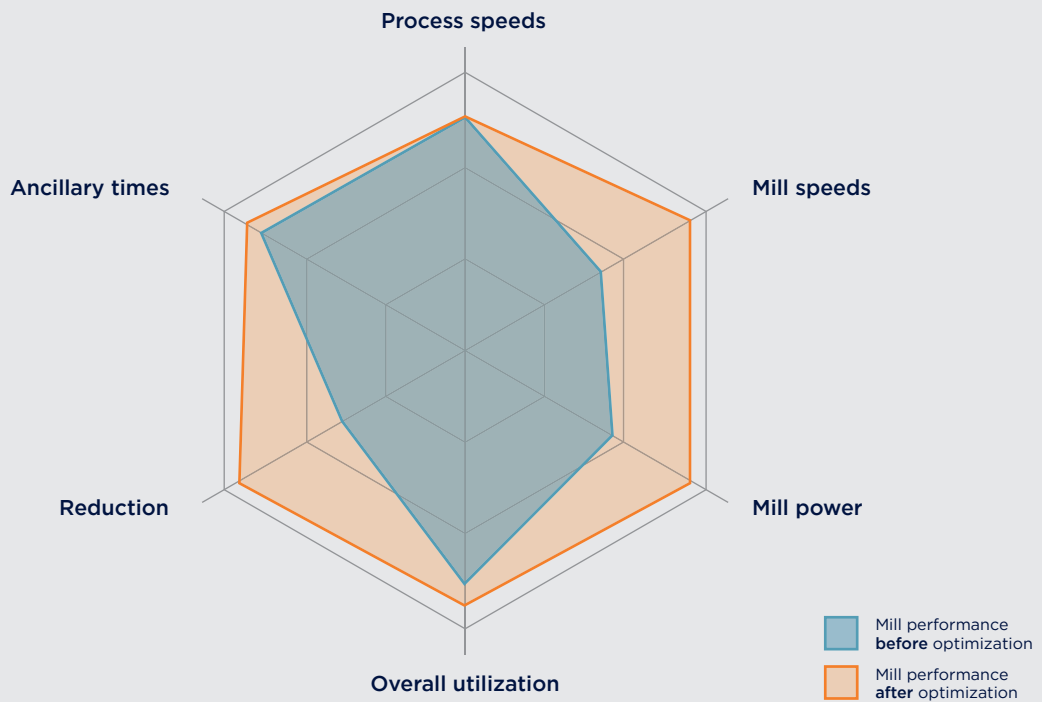

**FIG. 5:** Visualizing optimization potential with the Utilization Model: mill performance before (blue area) and after optimization (orange area). Visualizations such as these help to verify the effectiveness of the upgrade measures.



# THE NEXT STEP IN **LONG ROLLING FOR AUTOMOTIVE**

**HYUNDAI STEEL HAS INVESTED IN TWO INDUSTRY 4.0 COMPATIBLE  
LONG-ROLLING MILLS SUPPLIED BY PRIMETALS TECHNOLOGIES.**





**Hyundai Steel, based in Incheon and Seoul, South Korea, belongs to the Hyundai-Kia Automotive Group and runs six production facilities in South Korea and a further one in China.**

**FIG. 1:** Overview of the long-rolling complex of Hyundai's special-steels production facility in Dangjin, Korea.

Hyundai Steel tasked Primetals Technologies with the supply of a large bar mill and a small bar and wire rod mill for its Dangjin plant. The two multi-line rolling mills are capable of producing an annual one million tons of special steel billets as well as straight and coiled bars, with dimensions from 5.5 to 350 millimeters. The products are used in the manufacture of engine and transmission components used by Hyundai-Kia Automotive Group. The processed grades include carbon, special alloy, spring, bearing, and free-cutting steel. Sensors and electronics integrate with mechatronic packages, thus equipping the mill for Industry 4.0 applications.

1.

## FIRST MILL: LARGE BAR MILL

The first mill is a large bar mill (LBM) that rolls blooms into finished large round and square products, as well as into intermediate billets. A 2-high reversing breakdown stand is followed by a finishing and sizing train with continuous-gap-adjustment stands equipped with an under-load roll-parting system for automatic gap control. The mill's capacity of one million tons per year is split into some 800,000 tons of billets that serve the second mill, and 200,000 tons of other large bars. The product mix includes 150 mm and 180 mm billets, 80-350 mm rounds and 85-180 mm finished squares that are



10-12 meters in length. The starting bloom is 530x390 mm with lengths of 3.5-8 meters, weighing 5.7-13 tons. The mill runs at a maximum speed of 1.1 meters per second with a maximum production rate of 200 t/h. The produced bars measure 4-12 meters in length, with bundles weighing 2-10 tons.



### BREAK-DOWN MILL

This mill comprises a 2-high housing-type reversing stand, with rolls having a maximum diameter of 1,200 mm and a barrel length of 2,600 mm. At both sides of the mill, lineals with tilting fingers operate the pass change of the rolling stock. Complete with hydraulic capsules for the positioning of the bottom roll, the mill is designed for fully automatic operation and ease of maintenance.





## **CONTINUOUS FINISHING AND SIZING TRAIN**

The continuous finishing and sizing train allows for the whole range of sizes and shapes to be rolled using feeds that were prepared in a uniform pass sequence in the break-down mill, with only a few variants required for square products and larger rounds. The train features Red Ring Series 5 stands and Continuous Gap Adjustment technology.





## DIVIDING SHEAR

Round bars up to 140 mm are divided by the start-stop flying crank shear with a 270-ton nominal cutting force. The shear also provides front and tail-end crop cuts, which are collected in a bucket below mill floor level. A software program optimizes the cut lengths according to the actual bar weight and size, compensating for differences in bloom weight and crop amounts, while ensuring that only multiples of commercial length are processed by the subsequent cut-off station.



## CUT-OFF STATION

Bars grouped in layers are processed at the cut-off station for commercial length cutting. The station comprises two horizontal saws equipped with a 1,800-mm-diameter metallic disk. The disk is appropriately encased to avoid spilling cooling water onto the bar, thereby preventing bar-surface damage or undesired hardening effects. The cut-off process is fully automated, including the position/speed recalculation required to compensate for disk wear.



## 2.

## SECOND MILL: SMALL BAR AND WIRE ROD MILL

The second mill—a small bar and wire rod mill (SBWRM)—combines lines of small bars, rods, and bars-in-coil. Billets are rolled in a continuous rolling mill with original Red Ring Series 5 stands. The rod outlet features Morgan equipment such as No-Twist Mills and Reducing/Sizing Mills, High-Speed Laying Head, and Stelmor Conveyor. With an annual capacity of 800,000 tons, the SBWRM produces some 400,000 tons of wire rod, 300,000 of small bars, and 100,000 tons of bars-in-coil. The product mix includes 5.5-26 mm wire rod, 16-100 mm rounds, and 16-60 mm bars-in-coil. The starting materials are 150 mm and 180 mm billets produced by the large bar mill; 200 mm billets can also be used. The mill runs at a maximum speed of 110 meters per second for wire rod and 18 for bar, with a maximum production rate of 160 tons per hour. Straight bars are finished-sized by a Kocks block and produced in 4-10 meter lengths in 1-5 ton bundles.



Finalized coils of wire rod have an inner diameter of 900 mm and an outer diameter of 1,250 mm. The bars-in-coil are finished-sized by a Kocks block and have a diameter of 1,000 (inner) and 1,350 mm (outer). Coils from both the wire rod and the bar-in-coil lines weigh 1.7-3 tons, and are handled by a common combined vertical and horizontal conveyor system.

### BAR-IN-COIL OUTLET

Bars-in-coil are conveyed by a turndown into the pouring reels, with a high-speed switch alternately directing bars into the two pouring reels. The turndown is equipped with cluster rollers to prevent scratching of the bar. Pinch rolls facilitate the entrance of the bar to the reels, which are equipped with wear strips on the outer rotating drum.

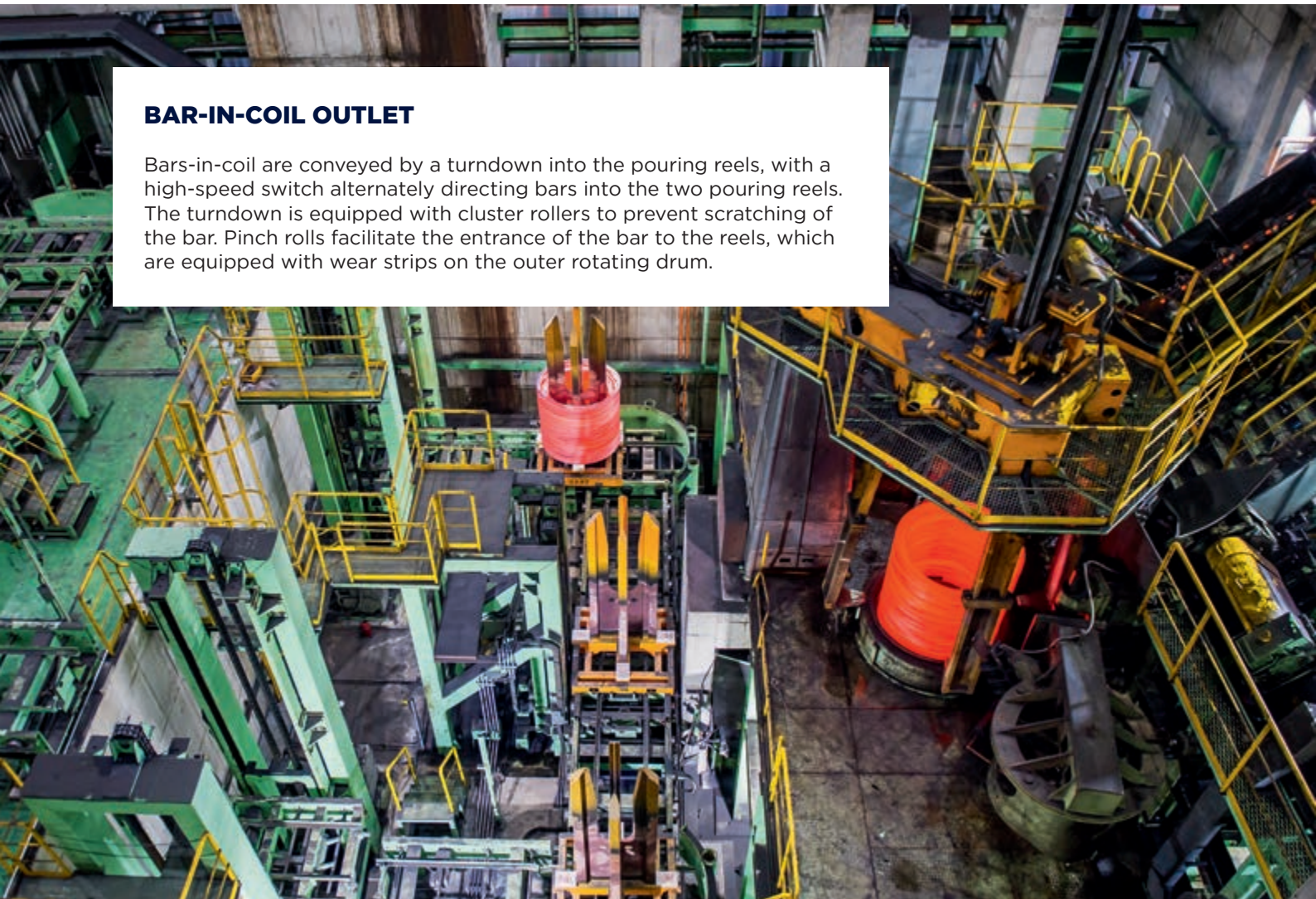



50/10TON

Rotem



## **CONTINUOUS ROLLING TRAIN**

The continuous rolling train comprises 18 Red Ring Series 5 stands, arranged in alternating horizontal and vertical configuration. Three sizes of stands are used, with full interchangeability within each size.





## FINISHING MILL

Using a Vee configuration, the finishing mill features an 8-stand Morgan No-Twist Mill with 230 mm ultra-heavy-duty interchangeable roll housings. This design ensures the optimum configuration for the size range required as well as reduced roll cost and improved section control, allowing a wide range of grades to be rolled.



**Hyundai plans to produce 400,000 tons of wire rod and 600,000 tons of straight bar and bar-in-coil per year.**

## STELMOR CONTROLLED COOLING CONVEYOR

The Morgan Stelmor Conveyor incorporates a wide range of processing conditions in a single system, including fast, slow, or hybrid cooling, to produce a broad spectrum of carbon and alloy steel grades. This flexibility, coupled with controlled temperature rolling, allows more grades to be produced in a directly useable condition, thus eliminating or accelerating downstream processes such as recrystallization and solution treatment.





# THE METAL OF KINGS

**PRIMETALS TECHNOLOGIES CONTINUES ITS LONG TRADITION  
OF PIONEERING SUPERIOR SOLUTIONS IN ALUMINUM ROLLING.**





**FIG. 1:** Aluminum coils, ready for delivery, produced at a state-of-the-art production site.

Aluminum is one of the world's most versatile metals and still in high demand. Primetals Technologies has been responsible for a large number of innovations that have shaped the way aluminum is produced today. Looking to the future, Primetals Technologies aims to support aluminum producers in taking their operations to the next level of productivity and efficiency with advanced digital solutions.

A material that may have been aluminum was first mentioned by the Roman historian and encyclopedist Pliny the Elder (AD 23-79). What's more certain is that aluminum was first electrolyzed in 1825 by the Danish physicist and chemist Hans Christian Ørsted. Thanks to its rarity and brilliant shine, in the mid-19th century aluminum was known as "the metal of kings." The first known use of aluminum was for bas-relief medals of Napoleon III and a rattle for his baby son.

As production scaled up, the price of aluminum fell rapidly and its use in consumer products became common from the early 1900s onward. The gradually increasing availability of electrical power went hand-in-hand with the growth in manufacture of this metal. Aluminum and aluminum alloys have

since become indispensable components in an incredible number of products for a host of industries. Thanks to its unique properties and characteristics, aluminum is increasingly being used as electrode carriers in lithium-ion batteries, for battery enclosures, solar panels, railway transport, and in many other fields.

The versatility of aluminum products in everyday life is directly connected to the pioneering advances and introduction of new technologies and solutions for the production and rolling of aluminum. Heritage companies of Primetals Technologies, including Loewy, Robertson, Morgan, Davy, Clecim, Cosim, Kvaerner, VAI, MHI, IHI, have been at the forefront of these devel- ➤



2.



3.

**FIG. 2:** Ulsan Aluminium 3-stand tandem hot finishing mill. Ulsan produces high-grade automotive coils for Korea's key vehicle manufacturers.

**FIG. 3:** Successful 1+4 hot-mill project at South West Aluminium. It took only 26 months to the first coil and a total of seven months for commissioning.

**FIG. 4:** Air-Bearing ShapeMeter installed at Ding-sheng New Materials on a 2,300-mm wide rolling mill producing 6  $\mu\text{m}$  foil at a width of 2 meters.



4.



**“ Primetals Technologies has helped us to reduce investments in our new projects, improve product quality, and be profitable in the market.”**

**Dong Qingliang**  
Director of Engineering, Dingsheng

opments since the mid-1930s. Primetals Technologies is continuing this tradition to push the limits of aluminum-rolling technology.

The technological portfolio of Primetals Technologies for rolling aluminum comprises hot- and cold-rolling mills, foil mills, and bright-finishing mills. These technologies are fully equipped with the latest automation, process control, and environmental solutions. With a track record of more than 350 successfully completed projects for new mills and mill modernizations, Primetals Technologies today is one of the world's leading suppliers of aluminum rolling technology.

### STEADY IMPROVEMENTS

Developments in aluminum rolling have and will continue to focus on the ability to roll faster, thinner, and wider, coupled with enabling even higher outputs, tighter product tolerances, enhanced operational flexibility and efficiency, increased plant availability, reduced costs, and maximum environmental compatibility. A selection of the many innovations implemented by Primetals Technologies is highlighted below.

Two predecessor companies of Primetals Technologies, Robertson and Morgan, were the first to replace grease-filled bearings with fluid-film bearings. This enabled a dramatic increase in rolling speeds and thus production output. The application of roller-element bearings further enhanced mill and product performance.

Primetals Technologies was the first company to introduce hydraulically activated automatic gauge control (AGC) and one of the first to focus on the development of automatic flatness control (AFC). Both of these systems are crucial for high-speed rolling, particularly for foil mills. To date, Primetals Technologies has

installed more than 300 proprietary AGC and AFC systems in cold and foil mills.

Other highly specialized products from Primetals Technologies include SmartCrown rolls, which are used on wide hot aluminum mills, non-contact shape-measurement systems, and ISV Spray Bars, which can be implemented on all mill types—from hot mills to foil mills. Control features include all the well-known profile, flatness, and gauge control modes. Additional features such as a coil-eccentricity compensation model are also used. Well-developed Level 2 systems with process models based on the metals-production expertise of Primetals Technologies complete the offering. These products, control schemes, and models are combined with state-of-the-art control systems to deliver fully integrated, optimized solutions. This results in the highest-possible product quality.

The 6-high mill of Primetals Technologies is known as the Universal Crown Mill (UCM). It can easily achieve speeds of 2,000 meters per minute at strip widths of 2,250 millimeters. All rolls in UCMs are parallel to each other. This offers a distinct advantage over contoured rolls in that the peripheral roll speed remains constant across the strip width. The result is a highly uniform strip finish and improved flatness control—as required for automotive and lithographic sheet.

Modern 4-high foil mills supplied by Primetals Technologies now regularly achieve line speeds of 2,000 meters per minute at strip widths of 2,000 millimeters. In fact, rolling speeds like these were pioneered by Primetals Technologies at a time when no other company was able to supply mills of comparable performance. Coil weights were also significantly increased to boost productivity. The seamless integration of technology, mechanics, electrical engineering, automation, and process control, is one of the main rea- ➤

sons why plants supplied by Primetals Technologies achieve superior performance levels.

### NEW DEVELOPMENTS

All aluminum producers today are focused on improving yield, reducing operating costs, and minimizing downtime. Primetals Technologies is working tirelessly to address these issues, as illustrated in the following examples.

Investigations are currently underway to adapt Multi-Purpose Interrupted Cooling (MULPIC) systems used in steel plate rolling mills for application in aluminum mills. The accelerated cooling offered by MULPIC will allow coil temperatures to be reduced even more quickly in order to minimize the time that a coil is held between processing steps—all part of the “lean philosophy” that many producers adhere to.

Further improvements to AFC and AGC will contribute to higher yields. For example, advanced mass flow and coil-eccentricity compensation are now capable of minimizing off-gauge lengths and decreasing variations in the thickness bandwidth respectively.

Production performance is further enhanced by applying area and weight optimization in foil rolling to obtain as much yield as possible from the input material. More precise thickness control allows the target thickness to be adapted up or down to either maximize or minimize the rolled length while still remaining within the tolerance values. This maximizes yield per input ton. Solutions are also available to minimize

scrap from trimmed edges for unrivalled cropping- and length-width optimization.

### 3 STAGES OF DIGITALIZATION

Digitalization is being adopted by the metals industry worldwide and Primetals Technologies is developing and implementing new digital innovations for aluminum producers. As the capacity of computers and networks increase, big data applications have become a reality and can now be used to advance aluminum-production technologies. Primetals Technologies is currently exploring the application of AI algorithms, specifically machine learning and deep learning, for application in aluminum-rolling technologies.

The digitalization experts at Primetals Technologies see digital transformation as a phased transition that should be made in partnership with their customers. The transition comprises three main stages:

**Stage 1:** Conventional production units such as individual hot mills and cold mills become smart units using smart sensors and actuators, condition monitoring systems, robotics, and other advanced technologies. Smart sensors with enhanced diagnostic functionalities are being increasingly integrated into Air-Bearing Shape-Meters and ISV Spray Bars. The Asset Life Expert (ALEX) system from Primetals Technologies is a powerful, next-generation condition-monitoring system that can be implemented for all production-relevant equipment.

**Stage 2:** Individual smart units are connected to one another, resulting in a smart aluminum plant. The

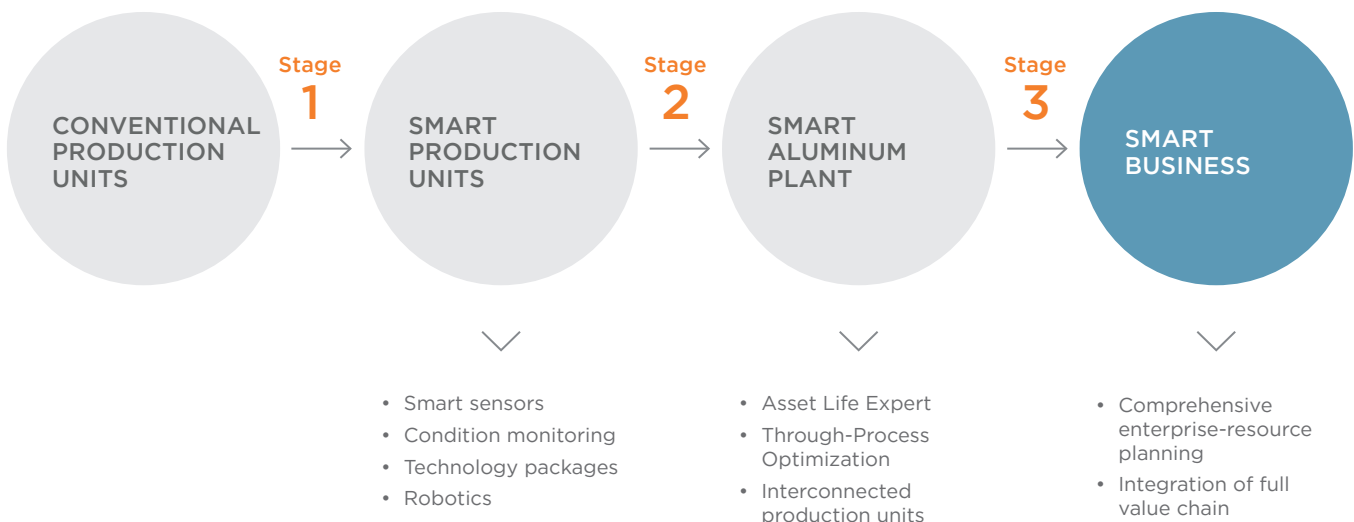



Through-Process Optimization (TPO) system from Primetals Technologies connects individual production units within one system for seamless operation and diagnostics. Both ALEX and TPO are scalable and can be implemented in stages.

**Stage 3:** The smart aluminum plant is now connected to areas beyond the immediate production chain, such as raw-material procurement and order fulfillment, by enterprise-resource planning (ERP) software and other smart solutions. This step achieves full digital integration of the entire value chain. Primetals Technologies offers powerful technology packages that are compatible with existing ERP solutions such as SAP, enabling aluminum producers to become smart businesses.

### SUCCESSFUL PROJECTS

As Primetals Technologies strives to reach the highest levels of customer satisfaction for all of its products and services, the teams involved in the company's recent aluminum-rolling projects are proud of the excellent feedback they have received from producers. One highly successful project was completed in 2019: China's largest foil producer, Jiangsu Dingsheng Aluminium (Dingsheng), contracted Primetals Technologies to upgrade and extend three of its production sites. For this project, Primetals Technologies supplied 60 sets of Air-Bearing ShapeMeters in addition to ISV Spray Bars, roll load cylinder position measurement transducers, and four packages of spare parts.

On completion, Dong Qingliang, Director of Engineering at Dingsheng New Materials Group, said: "Primetals Technologies has met our requirements—and has helped us to reduce investments in our new projects, improve product quality, secure a competitive advantage, and be profitable in the market." He added that, "so far, all of our projects with Primetals Technologies have been completed on time, and final acceptance has been straightforward. Our expectations were fully met."

### EARNING THE CROWN

Primetals Technologies is renowned for its engineering and plant-building competence across the entire spectrum of aluminum-rolling technologies. With continued emphasis on developing and implementing superior solutions for the rolling of aluminum, Primetals Technologies remains focused on ensuring that the "metal of kings" will rightly take its crown as the "king of metals"—in terms of quality, dimensional tolerance, and productivity. ●

**Dr. Lawrence Gould**, Fmr. Managing Editor, Metals Magazine

**Sandip Samanta**, Head of Technology, Plate and Aluminum Rolling, Primetals Technologies U.K.

**Phil Lawlor**, Senior Key Expert, Aluminum Rolling, Primetals Technologies U.K.



## ADVANCING DIGITALIZATION IN ALUMINUM ROLLING

Sandip Samanta, an expert in aluminum rolling at Primetals Technologies, has made it his mission to promote all aspects of digitalization.

### What do you find particularly exciting about aluminum rolling in 2021?

**Sandip Samanta:** Aluminum rolling is highly automated, but it is the adoption of the Industrial Internet of Things and the integration of artificial intelligence into aluminum rolling that I find most fascinating. This presents an opportunity to synchronize all process steps and maximize profit.

### Can aluminum producers benefit from digitalization at relatively low cost?

**Samanta:** There have been tremendous steps forward in computing power, network bandwidth, smart sensors, and robotics, all of which are major contributors to digitalization. With prices for these technologies plummeting all the time, aluminum producers stand to benefit significantly from digitalization.

### Is domain-specific knowledge essential to advancing digitalization in aluminum rolling?

**Samanta:** Data science has come a long way over the last few years, leading to the development of numerous algorithms that can be applied to the aluminum rolling industry. However, the key to success lies in identifying and configuring appropriate machine learning or deep learning algorithms based on a thorough understanding and in-depth knowledge of the processes that are specific to aluminum rolling.

# PLANT MAINTENANCE

## DONE THE EASY WAY

**MAINTENANCE AND ASSET TECHNOLOGY (MAT) IS DESIGNED TO KEEP STEEL PLANTS IN PERFECT SHAPE. MAT ARRIVES PRE-CONFIGURED FOR EASE OF USE AND DELIVERS IMMEDIATE, ACTIONABLE INFORMATION.**

**Every day, plant and maintenance managers need to find the right balance between optimal reliability and cost. MAT, the new solution from Primetals Technologies, is here to help.**



**FIG. 1:** MAT provides actionable information whenever needed—and enables steel producers to increase efficiency in maintenance.





Digitalization and improvements in knowledge management have been impacting almost all areas of steel production, and maintenance is no exception. Every day, plant and maintenance managers need to find the right balance between optimal reliability and cost. Engineers and operators require precise information on what tasks they are expected to complete by what deadline. Primetals Technologies has developed Maintenance and Asset Technology (MAT) to address all these issues—and to make the lives of maintenance workers much easier.

In order to increase efficiency in maintenance, MAT provides everyone who works with the system with actionable information. This means that each user is supported in their specific role. In addition, MAT can be implemented in a pre-configured state, giving maintenance staff a head start in terms of streamlining their maintenance processes. The goal of MAT is to maximize the return-on-investment of all production-relevant assets (i.e. a plant's equipment) whilst minimizing the costs associated with production, labor, and raw materials. With MAT, a plant's performance »

## Primetals Technologies accompanies steel producers throughout the implementation process of MAT and beyond.

becomes far more predictable, thereby enabling reliable and effective enterprise resource planning and order scheduling.

### SOFTWARE-AS-A-SERVICE

MAT can be obtained as a software-as-a-service solution, which means that maintenance and plant managers don't have to concern themselves with complex software installations, update procedures, or connectivity issues, because the MAT specialists take care of everything. Primetals Technologies is also responsible

for hosting and administrating the system, regular updates, security, and archival tasks, which positively impacts costs and increases convenience. On-premise installations of MAT are also available, if desired. And for those who need it, there is a mobile version of MAT that can be used on tablet computers.

### WHAT IS ACTIONABLE INFORMATION?

One of MAT's key benefits is that it provides all maintenance staff with information tailored to the position of the respective employee. While other systems are only capable of generating abstract information about issues that need to be resolved or tasks that should be executed, MAT supports workers with actual guidance as to where a problem is located and what needs to be done to resolve it. MAT comes pre-configured for all portfolio elements of Primetals Technologies and includes:

- Templates for the creation of asset-specific maintenance strategies
- Analysis of risks, such as equipment failure or potential downtime
- Guidance toward preventive, condition-based, or reliability-centered maintenance processes
- Provision of best-practice recommendations
- Analytic and predictive features that use statistical modeling, neural networks, artificial intelligence, and machine learning
- Efficient spare-parts management

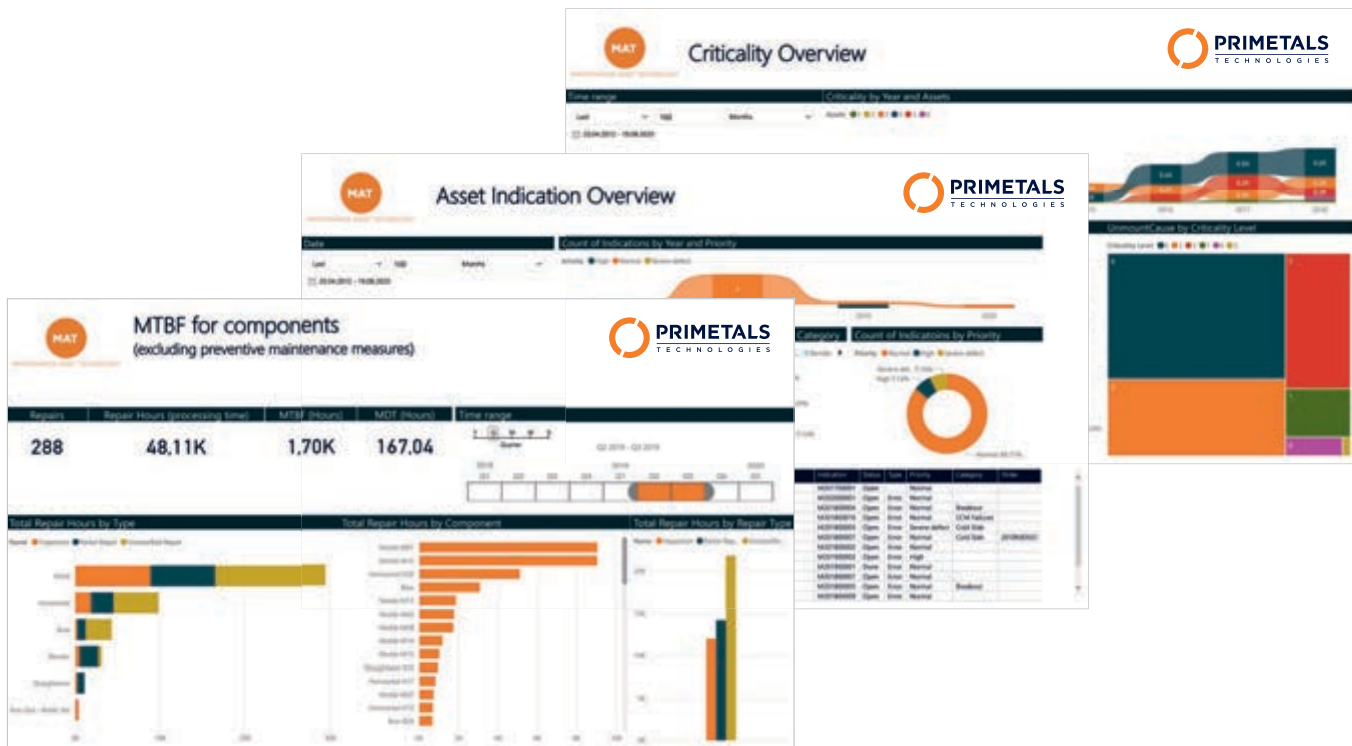

**FIG. 2:** MAT empowers organizations to create and modify reports (or select from a set of pre-loaded reports), and to output them as text, PDFs, charts, or graphs.



## A WIDE RANGE OF POWERFUL FEATURES



### ASSET TRACKING

MAT provides instant access to component-part maintenance history, allowing staff to ascertain how often a particular part has been repaired or replaced. Data analytics help to make maintenance more predictable and planning more efficient, thereby reducing ownership costs and boosting productivity.



### ADVANCED SCHEDULING

MAT's work-order-scheduling module allows work orders to be assigned to on-site and field technicians. Advanced visual scheduling makes use of visual tools for managing human resources and equipment, thereby increasing efficiency and minimizing downtime.



### RULES EDITOR

The rules editor is a maintenance-assistance tool that offers rule-based suggestions for recurring scenarios. Users can define the suggestions that should be given in any particular situation, which helps to standardize and therefore streamline processes.



### WORK-ORDER TRACKING

This graphical support tool is designed to track work orders as well as progress toward completion based on user-defined criteria. Work orders can be created at the click of a button and assigned to on-site or field technicians.



### PORTABILITY

MAT runs on tablet computers for on-site and offline use. The mobile app allows service engineers to access work orders, log hours, and add notes offline and synchronize the data later when online. MAT is designed to provide instant access to all knowledge resources and built-in assistance features on the fly, making it a reliable mobile companion.



### SEAMLESS INTEGRATION

MAT can interface with various third-party software such as enterprise resource planning (ERP) systems, automation systems, condition monitoring systems, or any other solution with standard application programming interfaces (APIs). Consequently, maintenance-relevant processes are streamlined and redundant tasks are reduced or eliminated entirely.

- Up-to-date information of asset health across the complete production chain
- Integration into the e-services from Primetals Technologies—such as the digital spare-parts e-shop m.buy, the plant-documentation platform m.doc, and the augmented reality services bundle m.ario

### A MODULAR SYSTEM

MAT comprises four smart modular packages: Predictive Maintenance, Planning & Shutdown Optimizer, Reporting & Business Intelligence, and Strategic Asset Management. While highly customizable, MAT comes pre-configured and packed with all the essential features, from criticality assessments and maintenance strate-

gies for specific equipment, to procedures, documentation, and checklists for responding to specific alarms.

Primetals Technologies accompanies steel producers throughout the entire implementation process of MAT and beyond. The experts behind MAT provide support and guidance from the earliest stages of a MAT project, from initial consulting, all the way through to integration, configuration, and training. ●

**Klaus Frauenhuber**, Head of e-Services

**Michael Weinzinger**, Product Manager, Maintenance and Asset Technology (MAT)

(Both with Primetals Technologies Austria)

Maintenance strategy	Reactive maintenance	Preventive maintenance	Condition-based maintenance	Reliability-centered maintenance with MAT
<b>Approach</b>	Repair or exchange after failure occurs	Scheduled, periodical service	Analysis of condition monitoring data to predict time of breakdown; exchange or repair before failure	Identification of optimum maintenance strategies for each individual asset through dynamic data analysis; inclusion of data from other processes like production. Dynamic evaluation of asset priority based on criticality analysis
<b>Application</b>	Non-critical assets	When equipment condition or criticality is unknown	Critical equipment	Holistic approach for complete maintenance organization, incorporates all previous maintenance strategies
<b>Goals</b>	Maximum utilization at low cost of maintenance	Maintain condition of equipment	Avoid costly reactive repairs and consequential damages; plannable maintenance activities and shutdowns	Increase overall equipment reliability and availability; predictive analysis of situation and provision of actionable information
<b>Challenge</b>	Potential consequential costs of failure for damages	Effect of activities and condition of equipment unknown	Not everything predictable, no interconnection with other processes	High maturity of maintenance organization required; time and investment required

**FIG. 3:** MAT's approach, application, goals, and associated challenges, compared to other maintenance systems and practices.



## BESPOKE FUNCTIONS FOR EACH ROLE



### EXECUTIVES

Executives overseeing the entire operation need to track and compare plants and assets. This includes identifying high-performers and under-performers, and determining what makes them succeed or fail. They must also be able to assure the plant's stakeholders that everything is running smoothly and that all assets are being operated in a responsible fashion. MAT enables executives to generate informative visualizations of large-scale assets and provides them with either a regional or company-wide perspective.



### PLANT MANAGERS

Plant managers must ensure plant production is predictable, safe, and efficient. They need permanent access to key performance indicators to evaluate the performance of individual production units. When issues are reported, managers rely on accurate information for audits and course corrections. MAT provides a complete, consistent view of the asset health of all production equipment. MAT allows engineering, maintenance, and operations staff to collaborate and solve problems more effectively and efficiently.



### MAINTENANCE MANAGERS

Maintenance managers must review upcoming tasks before they attend production-scheduling meetings. Maintenance, reliability, and integrity engineers need to monitor and manage equipment health while spotting trends and bad actors with ease. They need to know what engineering changes were made in the past and be capable of analyzing data. MAT combines various methods of analysis and gives maintenance managers hints for how to improve and ensure worker safety, equipment reliability, and asset integrity.



### ENGINEERS

Engineers must be able to swiftly identify potential operational problems and implement the right solutions. They need to determine what has changed during the maintenance and reliability program. Most importantly, they need to know that the data is trustworthy so that they can investigate, troubleshoot, and make fast and informed decisions. To engineers, MAT's actionable information means having peace of mind.



### OPERATORS

Operators need access to condition and maintenance data without delay—and without wasting time determining what data is relevant and what data is redundant. They must review as-operated data and historical data alike to understand what has changed and why certain engineering decisions were made. MAT gives operators the “big picture” and takes into account both maintenance and production-related information.

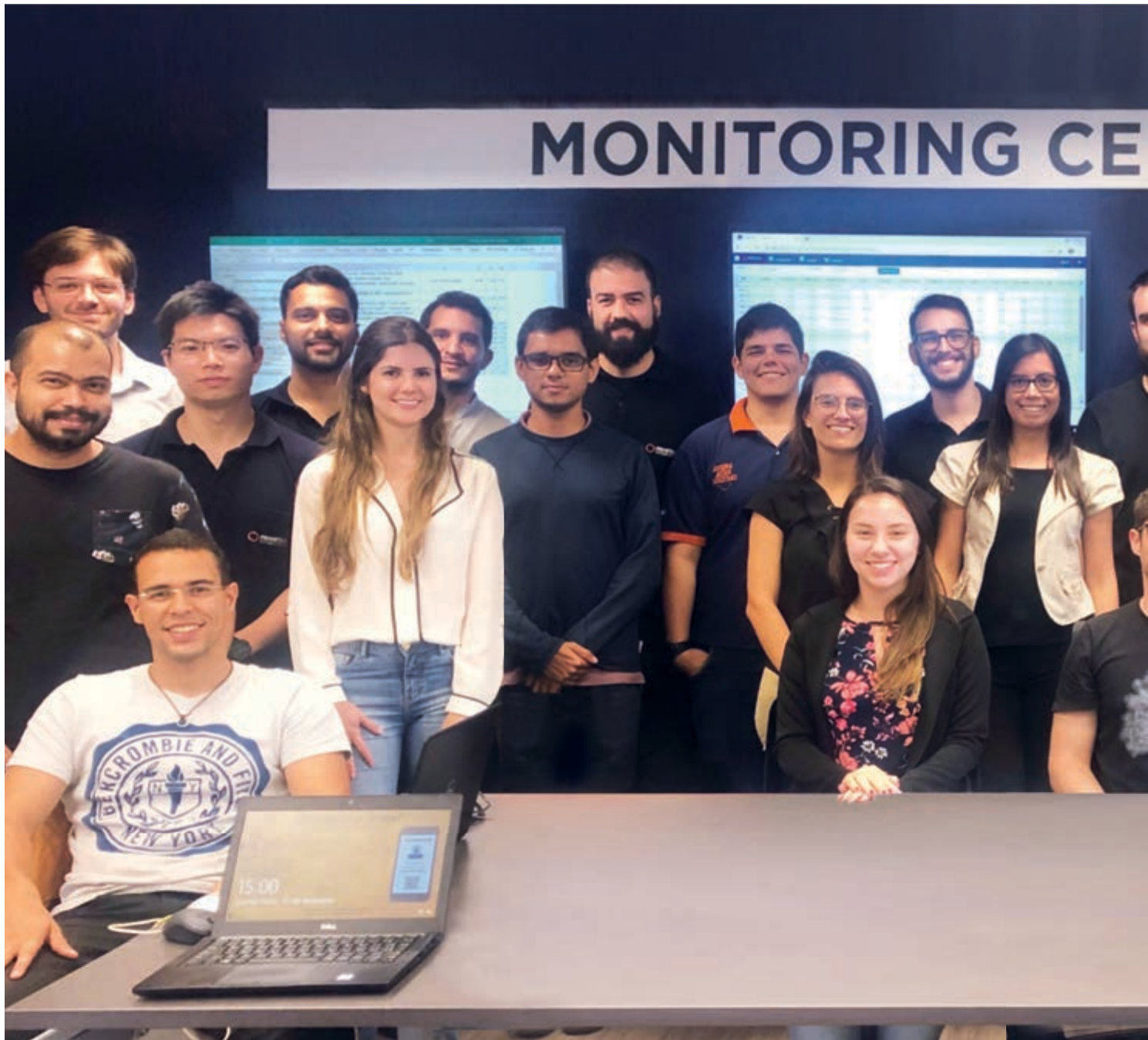

# CONNECT YOUR PLANTS **BOOST YOUR RESULTS**

**GERDAU AND PRIMETALS TECHNOLOGIES ARE PIONEERING A NEW METHOD TO CONNECT, MONITOR, AND SERVICE MULTIPLE PLANTS.**





**FIG. 1:** Gerdau EAF process specialists meet at the Monitoring Center Belo Horizonte to exchange experiences and best practices.

Covid-19 disclaimer: All photos featured in this article were taken prior to the pandemic.

Together with Brazilian-based steel producer Gerdau, Primetals Technologies has established a new way of monitoring a large number of electric arc furnaces—via a remote connection. While Gerdau profits from streamlined operations, a reduction in labor, and the expertise of the Primetals Technologies staff, it is the opportunity to benchmark production efficiency and output of all plants involved that is the largest benefit of this novel solution.

Primetals Technologies has been working with Gerdau for more than 10 years—and over time, the two companies have formed a dependable partnership. Primetals Technologies has been providing comprehensive support in the development and evolution of Gerdau’s process models for the electric arc furnace, “Meltdown” and “Scrap Optimization.” The Meltdown model is used in EAF-based plants as an intelligent system that guides operators toward achieving great process stability and increased productivity, while Scrap Optimization is a powerful solution that enables Gerdau to plan and optimize scrap purchasing on mid-term horizons, taking into account multiple plants and various sources of scrap.

The Scrap Optimization solution includes the modules “Slag Simulator” and “Bucket-Layering Optimizer,” which offer the additional benefit of facilitating the training of new employees. Entire heat simulations encompassing all process inputs and EAF parameters can be performed virtually and in advance, enabling Gerdau to meet the most demanding customer requirements in real-world production.

The Meltdown model is currently in use in several of Gerdau’s EAFs, while Scrap Optimization has proven invaluable to supply chain operations at Gerdau North America. The successful implementation of the two models has resulted in a better way of monitoring and recording EAF-related production data: the data of multiple plants is now available in standardized form, making comparisons and benchmarking much more straightforward. But internal plant-performance benchmarking is not the only advantage the models have presented Gerdau with. They also make it easier to systematically accumulate operator knowledge and preserve the experience and expertise of Gerdau’s veteran staff.

### CONNECTED SERVICES

As part of its strategy to increase production performance and product quality, Gerdau opened a remote Monitoring Center in Belo Horizonte, Brazil, in 2019. The role of Primetals Technologies, under the terms of a remote-services contract, is to monitor 9 EAFs in Brazil and the U.S.A., focusing on high levels of accuracy while also continuously improving the EAF pro-



### PLANTS IN MANY COUNTRIES

Gerdau is an international steel producer and currently operates production facilities in 10 countries including Brazil, the U.S.A., and Mexico. The picture shows one of Gerdau’s plants in Brazil.

### 9 EAFS, AND COUNTING

The connected services network created by Gerdau and Primetals Technologies is on a clear growth trajectory. As of late 2020, it already stretched over 9 EAFs in as many plants.



cess models. On a day-to-day basis, the main tasks are data analysis to facilitate the fine-tuning of parameters for the metallurgical models, data-quality checks, support for equipment safety, generating process reports for operational support, and benchmarking.

The remote Monitoring Center is also used for training, for providing remote assistance to users, and as a hub for investigating potential areas for ongoing process improvement. A multidisciplinary Primetals Technologies team—comprising metallurgists, automation engineers, and data scientists—handles the analysis of “big data” and monitors EAF furnace performance in close collaboration with the Gerdau team.

Initially this collaboration was focused on the EAFs, but it has gradually been extended to encompass other solutions such as the “Gerdau Alloying Model,” which uses artificial intelligence to improve ladle furnace operation, as well as a ladle planning optimizer that ensures the availability of ladles at the melt shop at the correct thermal condition. Further solutions for other kinds of

furnaces, such as the BOF and EOF (electric oxygen furnace), are already part of the integration roadmap.

### SEAMLESS COLLABORATION

To ensure seamless collaboration and communication, Gerdau and Primetals Technologies are managing operations from a neutral office located at the Brazil location of Primetals Technologies in Belo Horizonte. Agile methodology is key to planning and tracking monitoring activities, and ensures high transparency in terms of targets and achievements. This fully collaborative approach enables the teams to respond quickly, provide immediate support, and maintain excellent service quality, while also consolidating gained insights and experience across both teams.

All changes to process models are well documented—and are subject to Gerdau’s strict validation process prior to approval for implementation within a live production scenario. The information architecture is based on a cloud environment, which enables all stakeholders to access reports and dashboards. Priorities »



### THE MONITORING CENTER

The Monitoring Center is located on neutral office where Gerdau and Primetals Technologies employees can work in close collaboration. The Monitoring Center supports Gerdau’s everyday operations.

### GERDAU’S HEADQUARTERS

This is where the insights provided by the connected services are applied. They are used by Gerdau’s staff to benchmark their EAFs, make better decisions, and preserve operator knowledge for the long term.

## A WIDE NETWORK OF PLANTS

Gerdau's operations span several countries in the Americas. The connected services provided by Primetals Technologies help to benchmark all of them.

### Cearense, Brazil

Products: long products  
Capacity: 189,600 tons/year

### Açonorte, Brazil

Products: long products  
Capacity: 500,000 tons/year

### Riograndense, Brazil

Products: long products  
Capacity: 415,000 tons/year

### Charqueadas, Brazil

Products: special steels  
Capacity: 425,000 tons/year

### Petersburg, Virginia

Products: long products  
Capacity: 1 million tons/year

### Cartersville, Georgia

Products: long products  
Capacity: 780,000 tons/year

### Gerdau Cosigua, Brazil

Products: long products  
Capacity: 1.6 million tons/year

### Pindamonhangaba, Brazil

Products: long products  
Capacity: 800,000 tons/year

### Açariguama, Brazil

Products: long products  
Capacity: 900,000 tons/year

## HOW GERDAU IS BENEFITING FROM CONNECTED SERVICES

The connected services provided by Primetals Technologies are at the cutting edge of innovation in the steel industry and present Gerdau with very tangible and unique benefits. One of the solution's strongest aspects is its scalability: the benefits listed below apply to all of Gerdau's plants that are part of the connected services network, which allows for comprehensive benchmarking.



Continuous evolution of the metallurgical models as a key strategy for standardizing operations, with a positive impact on Gerdau's production efficiency and overall financial performance.



Relieve process engineers of non-core activities (e.g., data preparation, report creation, and metallurgical model optimization), giving them more time to focus on the continuous improvement of plant performance across multiple sites.



Common governance, knowledge management, and benchmarking across multiple Gerdau plants.



Increased operational efficiency thanks to remote system assistance for all Gerdau employees using the process models.



Training and development of new professionals with a unique combination of skills (metallurgy, industrial IT, and automation) with a focus on a modern and agile culture.

## As steel production becomes more digital, the levels of integration between customers and suppliers is reaching new heights.

are agreed jointly, the speed and quality of the deliverables are measured every week as part of an ongoing evaluation process, and the accuracy of the models in each plant as well as financial indicators are also taken into account. The increased amount of transparency has added further to Gerdau's leading position as an Americas-based international steel producer.

### EXPANSION AHEAD

Gerdau and Primetals Technologies are planning to expand the collaboration model to other steel production stages and to new EAF-based plants in Mexico and Argentina. The Monitoring Center will bolster existing initiatives geared toward safer operations and the quality assurance of Gerdau products along the entire production chain.

At the same time, Primetals Technologies is looking forward to partnering with other steel producers who are determined to shape the future of metals. As steel production is becoming increasingly digital, the levels of integration between customers and suppliers can be taken to unprecedented heights. It is precisely this kind of strong alliance that allows for the application of new service models and the assurance of long-term success for all stakeholders.

The connected-services portfolio from Primetals Technologies will be made available globally and 24/7, and has been developed to cover a multitude of processes in the steel-production chain. The standardization of plant-specific data, the ability to introduce a common set of KPIs for multiple plants, and, most importantly, the capacity to minimize production downtimes and provide day-to-day support are all cornerstones of the new centralized monitoring and benchmarking setup—an innovative way of managing metallurgical and operational expertise that Primetals Technologies is pioneering together with its customers. ●

**Gabriel Lenna**, Head of Connected Services, Primetals Technologies Austria

**Pedro Cotta**, Monitoring Center Manager, Primetals Technologies Brazil



## PROVIDING STEEL PRODUCERS WITH REMOTE 24/7 SUPPORT

Gabriel Lenna is Head of Connected Services at Primetals Technologies. He aims to provide services to steel producers around the clock.

### What's next for Connected Services?

**Gabriel Lenna:** Primetals Technologies is setting up a global infrastructure to serve our customers 24/7. We are expanding our portfolio with additional services in the fields of plant optimization, predictive maintenance, and immediate support. We plan to significantly increase our level of integration with metals producers by providing direct connectivity to plants and a customer platform from where technical support can be obtained as if we were an extension of our customers' teams.

### What areas of steel production are you currently focusing on?

**Lenna:** The business model applied to EAFs will be extended to other areas, with casting being the next step. We have great competence in this field and many references. There are also synergies with our caster-maintenance workshops, and we can offer a unique and complete combination of expertise, providing support in technology, maintenance, automation, operations, and metallurgy.

### Are your Connected Services also available to steel producers other than Gerdau?

**Lenna:** Definitely yes, we are looking forward to serving other steel producers as well. We want to stay connected to them and support their business on a daily basis.



# GREAT PIONEERS

## THAT INSPIRE US



At Primetals Technologies, we constantly strive to pioneer new and groundbreaking solutions for the steel industry. We work with passion, inspired by our close partnerships with steel producers from all around the world. Another source of inspiration are the great pioneers that have come before us—innovators who have made a profound impact on the way we live and changed the course of history. In this series, we look at the life, the challenges, and the achievements of some of the most outstanding pioneers of all time.

TIMELINE

**1939**

Born Ishibashi Junko in Miharu, Fukushima, Japan.

**1958-1962**

Studies English literature and education at Showa Women's University.

**1969**

Forms Ladies Climbing Club: Japan (LCC), with the slogan: "Let's go on an overseas expedition by ourselves."

**1975**

Begins Everest expedition, reaches summit on May 16.

**1991**

Reaches summit of Mount Vinson, the highest mountain in Antarctica.

# JUNKO TABELI

## PIONEERING JAPANESE ALPINIST AND FIRST WOMAN TO SUMMIT MOUNT EVEREST

The time is just after midnight on May 4, 1975. Without warning an avalanche sweeps through Mount Everest's Camp II at 9,000ft, burying the team of 15 mountaineers and six Sherpa guides as they sleep in tents. Crushed beneath four other members of the team and briefly knocked unconscious, Junko Tabei is rescued by Sherpas from a neighboring tent and revived. It is days before Tabei can walk normally again. Undeterred, she collects herself and forges on into the death zone—alone except for her Sherpa—, reaching Everest's south summit twelve days later. Dealt yet another hand of uncertainty on discovering a narrow icy ridge that forms part of the border between Nepal and Tibet—and flanked by spine-chillingly vertical 15,000-foot drops—Tabei finds herself on the brink of a decision that will cement her place in history.

Junko Tabei (pronounced tah-bay-ee) would have been no stranger to teetering on the precipice, having spent most of her life treading the knife-edge between inequity and emancipation. In 1970s Japan, men were the undisputed breadwinners; even working women were considered little more than tea ladies, while promotion in the workplace was inconceivable. Which makes it all the more remarkable that housewife Tabei—who was frequently told she should be “raising children instead”—managed to find enough sponsorship to fund an all-female expedition to the summit of Mount Everest.

### DEFYING THE STEREOTYPES

Tabei was stigmatized as a weak child, with no sporting prowess and a susceptibility to regular bouts of pneumonia. Nevertheless, a passion for mountaineering was ignited on a primary school climbing trip to Mount Nasu, aged just 10. Captivated by the rocks, the landscapes, hot springs, and alpine smells, it was a revelatory trip that changed Tabei's life and made her even more hungry for the kinds of physi- »



### DID YOU KNOW ...?

- ... that around 75% of Japan is mountainous and the country has produced several world-class alpinists, including Yuichiro Miura and Ken Noguchi.
- ... that on November 19, 2019, a Plutonian mountain range was named in Tabei's honor: Tabei Montes. It follows the naming of land features for Sir Edmund Hillary and Sherpa Tenzing Norgay, Hillary Montes and Tenzing Montes. New names of features on Pluto honor historic pioneers who crossed new horizons in the exploration of the Earth, sea and sky, according to the International Astronomical Union (IAU).
- ... that the 4ft 9ins Junko Tabei was a housewife and mother of a 3-year-old daughter at the time of her Everest ascent, and by the time of her death had scaled the highest peaks in more than 70 countries.
- ... that the death zone is the point above 8,000 meters where there is insufficient oxygen for humans to breathe.
- ... that it was so difficult to find sponsorship for the Everest expedition that, to save money, Tabei's Ladies Climbing Club fashioned waterproof pouches and over-gloves from recycled car seats and made their own sleeping bags. Tabei also worked as an editor and taught piano and English to further subsidize the expedition.

**1992**

Reaches summit of Puncak Jaya, Indonesia, becoming the first woman to complete the Seven Summits.

**2000**

Completes postgrad studies on environmental impact of climbers on Everest at Kyushu University.

**2012**

Is diagnosed with peritoneal cancer.

**2016**

Dies in hospital in Kawagoe, aged 77.

**2019**

Google commemorates what would have been Junko's 80th birthday (September 22) with a Doodle.

cal experiences that were only possible outside of the classroom.

While studying English literature and education at Showa Women's University in Tokyo, Tabei became envious of a group of male students who were members of an alpine club. Inspired by her experiences at university and to a large extent driven by the way she had been treated by male climbers, some of whom believed Tabei was only looking for a husband, she founded the "Ladies Climbing Club" (LCC) in order to realize her dream of taking an all-female team of climbers to the Himalayas. Unprecedented in Japan, the club got off to a rocky start: at the time it was mandatory for any climbing club with aspirations of trekking the Himalayas to be a registered member of the Japan Mountaineering Association, and it took more than one application before the LCC was accepted. Once approved, though, it allowed the club to make the groundbreaking 1970 Annapurna III expedition in Nepal.

Bolstered by the success of Annapurna III, the LCC then set its sights on Mount Everest. Inevitably, the male alpine community at once declared the expedition impossible. Not only was the club forced to work relentlessly to obtain a highly restricted climbing permit for Everest, but Japan was also going through the oil shock of 1972/73 that hit the economy hard and made it incredibly difficult to secure funding—not least for an all-female group of mountaineers. Fortunately, major newspaper Yomiuri and TV station NTV came through with eleventh-hour sponsorship, but each member of the climbing team still had to come up with 1.5 million yen out of their own pockets, the equivalent of Japan's average annual salary at the time.

**“My impression of Tabei is one of strength, clear-mindedness, and determination. She believed in a person's will to succeed, and that all goals are achievable one step at a time.”**

Helen Y. Rolfe

Co-author of "Honouring High Places"

## ON THE PRECIPICE OF GREATNESS

The expedition to the summit of Mount Everest began in early 1975, following the same ascent pioneered by Sir Edmund Hillary and Sherpa Tenzing Norgay in 1953. But despite all the meticulous planning, nothing could have prepared the team for what happened in the early hours of May 4, when the avalanche devastated Camp II. Tabei had to be revived after being unconscious for about six minutes, and was forced out of action for three days until she could walk properly again. Yet there was never any question of quitting.

On May 16, Tabei and her Sherpa guide Ang Tshering, having been forced to leave the rest of the team behind, reached the South Summit of Mount Everest. The peak was now tantalizingly close, but despite all the physical and mental challenges of high-altitude climbing that she had already conquered, there was one more seemingly insurmountable obstacle that left Tabei facing potential heartbreak: a dangerously narrow, icy ridge that she had not expected at all, and that threatened to derail the expedition at the final hour. "I had no idea I would have to face that, even though I'd read all the accounts of previous expeditions," she later told *The Japan Times*.

The fearless Tabei figured out that by straddling the ridge and crawling sideways with her upper body on the Chinese side and her lower body on the Nepalese side, she could make it all the way to the top. Becoming the first woman to scale Mount Everest was a milestone achievement not only for female climbers, but for women everywhere. Typically modest, Tabei said of her achievement in a 1996 interview with *Sports Illustrated*, "All I felt was relief."

When Tabei returned home after the expedition she became a reluctant celebrity, receiving messages of congratulation from the Japanese government and even the medal of honor from the Nepali government. She said, "I did not intend to be the first woman on Everest," and in fact said she preferred to be remembered as merely the thirty-sixth person to have done so.

Tabei's simple love of mountains, combined with the hunger for new experiences she had felt as a child, kept her motivated for many years to come. After the Everest expedition, Tabei went on to complete the Seven Summits, the highest mountains on each of the seven continents, by climbing Kilimanjaro in Tanzania, Aconcagua in Argentina, Denali (formerly McKinley) in Alaska, Elbrus in Russia, Vinson Massif in Antarctica, and Puncak Jaya in Indonesia.

## SUSTAINABLE MOUNTAINEERING

In the 1970s and 80s climbing permits for Everest issued by the Nepalese government were restricted to one party per route per season, but the rules were relaxed in the 90s. This unwittingly turned climbing





**FIG. 1:** Tabei with Nobuko Yanagisawa and Mayuri Yasuhara in 1985

Everest into a leisure pursuit and opened the floodgates to thousands of climbers keen to earn kudos by checking off the Everest box. It meant that those with enough money could hire Sherpas and professional guides to do the heavy lifting, essentially making the ascent less of a challenge. Purest Tabei lamented the shift toward this kind of “big entertainment” and commercialization, calling these types of climber “Intensive Care Unit” climbers because of the life-support they could fall back on. She was adamant that “Climbing the mountain is its own reward.”

Ultimately, though, it made Tabei aware of the environmental damage being done to Everest as a result of the huge increase in the number of climbers. Once again Tabei found herself following in Sir Edmund Hillary’s footsteps, echoing his plea to “give the mountain a rest.” Inspired by Hillary’s environmental initiatives, Tabei became a champion for sustainable mountaineering, attending Kyushu University as a postgrad to study the degradation of mountain terrain caused by waste left behind by climbers, and also becoming director of the Himalayan Adventure Trust of Japan,

## CLEANING UP AFTER THE CLIMBERS

In February 2020 the Nepalese government announced an ambitious plan to mobilize its army to clear 35,000 kg of garbage from Everest and five other Himalayan peaks: Lhotse, Pumori, Amadablam, Makalu, and Dhaulagiri. The cost is estimated at 860 million Nepali rupees (\$7.5 million). This compares to the 10,000 kg of waste cleared from the region the previous year.

Garbage includes objects such as oxygen and cooking gas cylinders, climbing gear, and food wrappers jettisoned by climbers—as well as the unrecovered bodies of climbers themselves, some of which have been on the mountain for decades. In 2019, eleven deaths were recorded on Everest, and with iced bodies weighing as much as 150 kg, it makes recovery very difficult.

“**The summit of Everest was beautiful, without a single man-made object in sight. I was the first woman there.**”

Junko Tabei

a non-profit environmental group dedicated to preserving mountain environments.

Perhaps less well known than many other climbers throughout history, Junko Tabei’s story is no less inspiring. There is no doubt that her courage, determination, and sheer love for climbing changed the mountaineering landscape, not just in Japan but globally. Tabei’s milestone achievements at the top of the world paved the way for the next generation of female climbers, and toward the end of her life she was able to use her celebrity as a platform for environmental change. Once asked what advice she would give to her younger self, she answered, “Do not give up. Keep on your quest.” ●



PART 4:  
**WORKING  
FROM HOME**

# THE PIONEER'S GUIDE TO **BOOSTING CREATIVITY**

In this series, we look at different ways of getting the creative juices flowing. This time, we focus on techniques for maximizing productivity while working from home. With the right approach, it's possible to create a harmonious work-life balance that nurtures our physical, emotional, and mental well-being.



**“On average, remote employees worked 1.4 more days every month, or 16.8 more days every year, than those who worked in an office.”**

2020 study by Airtasker  
of 1,004 full-time employees

The nine-to-five schedule is a concept that dates back to the American labor unions of the 1800s. It is quickly becoming obsolete thanks to technology and the ability to work from anywhere. Working from home sounds ideal in theory, eliminating the daily commute and affording you the flexibility to arrange your own schedule, and potentially offering a better work-life balance. In practice, though, it can be a very different picture and it does take discipline; with a work life and a home life occupying the same space, it's often difficult to keep the two separate. So when you find yourself working from home—and most of us will at some point in our careers—how do you go about building a barrier between your professional and private lives so that neither bleeds into the other and you stay creative, productive, healthy, and safe?

For some professionals, such as writers, translators, or graphic designers working alone and, for the most part,

on a freelance basis, teleworking is the ideal set-up, offering tremendous flexibility in terms of time management. There are also employers who recognize the benefits of allowing their staff the freedom to work remotely either full or part-time, equipping them with all of the technology they require to work seamlessly as if they were physically in the office. Then there are extraordinary circumstances such as the coronavirus pandemic that are forcing us to entirely rethink the way we work. Whatever your situation, the shift in mindset required to move from an office to a home-working environment can be challenging; success in a home workplace depends on the creation of a working environment designed to promote efficiency and well-being away from the traditional office.

#### **WHAT IS WORK-LIFE BALANCE?**

Getting into the right frame of mind to be creative at work depends largely on having the right work-life »



balance and this is something we should not underestimate. But what does that really mean, and what does it entail? Essentially, work-life balance refers to how we prioritize our professional and private lives and how we can achieve a satisfactory equilibrium between the two. While the availability of sophisticated technology has made it easier to work remotely, by removing the importance of physical location it has also blurred the lines between our working and home lives. The internet, mobile technology, teleconferencing tools, and cloud-based software, for example, now enable us to work from almost anywhere. But what this also means is that we are in danger of being “always-on.”

A harmonious work-life balance has several positive effects, such as reduced stress, a lower risk of professional burnout, and a greater sense of well-being. Getting it right can have tremendous benefits for employers as well: lower overheads, reduced absenteeism, a more satisfied, motivated, loyal, and, therefore, more productive workforce, savings in office space, and a reduction in the company’s carbon footprint. Businesses have begun to embrace more flexible work schedules, making it a priority to accommodate their employees’ individual needs and helping to improve their mental and physical health. It is also a strategy that allows these companies to remain highly competitive, as this greater flexibility allows them to attract and retain top talent.

To achieve equilibrium, it’s also essential to remember that there is no perfect work-life balance, that the goal posts are shifting on an almost daily basis, and what

works for one person may not work for someone else. As long as we remain realistic, we can allow the balance to ebb and flow between work and home as demand dictates. It is more about your output than the number of hours you put in. Balance is a long-term goal, not a daily one. As founder of career mentoring group Boss in Heels, Heather Monahan, says: “It is important to remain fluid and constantly assess where you are versus your goals and priorities.”

### THE CREATIVE SPACE

Of course it depends on the individual, but working from home can generate unprecedented opportunities for clarity and focus, and creativity can improve as a result. Working in an environment where you feel relaxed, comfortable, and free from the distractions of the office—such as meetings or drive-bys from colleagues—can allow you to deliver some truly unique work. A little bit of distance from the traditional office can enable an objectivity that is so crucial for fresh thinking; without distraction we have quiet to think, and to look at the world outside of the office, from a different perspective. This is often an untapped source of inspiration and creativity.

Remote working can also result in a shift in the landscape in terms of personalities. Working from home can be an opportunity for less dominant personalities to shine. Some of the most creative voices are never heard in meetings, so for introverts who are less likely to speak up, working from home can be energizing. Meanwhile, because teleworking is very much based on trust, everyone is keen to show high levels of

**“Working from home is a great test for your creative skills because it demands you rethink how you work. Not just how you arrange your day, but how to make sure you’re not just sitting in one place for hours on end all by yourself.”**

Jon Wolanske

Creative Director, Goodby Silverstein & Partners

## THE PERFECT HOME OFFICE

### Occupational Health and Safety

Good health and safety practice means avoiding occupational pitfalls such as poor ergonomics, inappropriate lighting and room temperature, distractions, bad time management, and isolation.



Set up an ergonomic workstation: consider a height-adjustable desk (or a standing desk mount) and work standing up for 10 out of every 90 minutes. Your chair should have good lumbar support and be height-adjustable so that your knees are at a 90-degree angle when your feet are flat on the floor and your lower arms are horizontal.



The monitor should be at least arm's length in front of you, with the top of the screen at or below eye level, and ideally positioned at right angles to windows to prevent screen glare. While natural light is important, try to combine natural and artificial light to create a well-lit workspace.



Take frequent, short breaks (micro-breaks) and move about and stretch. Consider using software to set reminders and even coach you through a few exercises. You might even take advantage of these breaks to get a few household chores out of the way.



Maintain a consistent routine that takes into account when you are at your most productive. Avoid working long hours, or sleeping late on workdays—poor time management will only disrupt your routine and compromise your health.



Minimize stress by keeping distractions to a minimum. This will also help to avoid compromising your schedule, the quality of your work, and your productivity. Make sure arrangements are in place for children or dependent adults.

productivity, which can promote a broader depth of creativity from every employee as each voice competes to be heard.

For those who draw inspiration from personal connections and collaboration, the opportunities for strong connectivity through technology are numerous. The increase in internet speeds has made video conferencing widely available to everyone, allowing daily inspirations to be shared among colleagues, or even exercise classes or musical renditions to be livestreamed, or virtual coffee dates scheduled whenever a mental break is needed.

### STAYING PRODUCTIVE

It emerges that the golden rules for staying productive while working from home include having set working hours, taking regular breaks, and eliminating distractions. While remote working can be an opportunity to improve your work-life balance, it does take discipline to prevent your work from disrupting your personal life. It is vital to create habits that establish firm boundaries between the two; before you start work in the morning you might go grab a coffee from across the street or take a walk, mimicking the commute and allowing you to transition from one space to the other with a clear boundary and a clear head.

An increasing number of companies are recognizing that a more flexible work life is leading to a happier and more productive workforce, and are therefore coming to regard teleworking as an asset. Working from home is no longer a privilege, it is becoming the new norm, where trust is more important than ever. Trust is the attribute that underpins the most creative and high-performing teams. At the end of the day, inspiration can strike anywhere, which is perhaps why the flexibility of remote working invites innovative thinking, and creative people will always find a way to create—be it in the office, or at home. ●

“For us, there are two key concepts for the remote creative process: over-communicating, and most of all, trust.”

Juan Javier Peña and Ricardo Casal  
Partners and Executive Creative  
Directors, GUT

## IT'S ALL IN THE MIND

### Achieving Work-Life Balance

If you aim to achieve proper work-life balance, it makes sense to think of your work life and home life as two different states of mind—and learning how to switch between the two can be of great benefit. Here's how to get started.

- To create a state of home, try conjuring up a few relaxing memories—places and times that firmly establish a comfortable, welcoming, even cozy environment and that truly make you feel “at home.” It might be childhood memories of a summer vacation spent adventuring in the woods and paddling in the stream, family excursions, or helping Uncle George to restore his vintage Triumph Bonneville motorbike.
- Create a productive mental work state by thinking back to a project that thoroughly absorbed you and made time fly. Total absorption comes from doing something you are passionate about, and this will ultimately push you to be more creative and productive.
- Create physical spaces that represent “work” and “home” and fill each space with objects that reinforce the function of that space. Make sure you keep these spaces separate by establishing boundaries; prevent work-related objects from infiltrating your private space, and vice versa.
- Remember that whenever you enter your workspace, you are there to do just that: work. Avoid “social suck” at all costs—would you check Instagram or Twitter during a work meeting? It's a distraction, and unproductive.
- The impact of routine and structure on your state of mind cannot be emphasized enough. Without the commute the line between home and work becomes even more blurred, so use the time gained to inject some creativity into your routine by getting up early, exercising, breakfasting with the family—anything to fire you up for the day and inspire your best work.





## FEELING ISOLATED?

### Working on Your Own, Made Easier

While some may thrive in a less distracting environment, others may feel isolated and lonely. Working remotely means that a certain degree of isolation is par for the course, so maintaining co-presence and communication will require you to get creative in finding alternative ways to keep in touch. Here are a few tips to help make things easier:

- Talk to your superiors and colleagues about how (email, phone, messaging tools) and when (frequency) you will keep in touch and coordinate your availability.
- Create a communication network with other colleagues using teleconferencing and messaging tools. Bouncing ideas off colleagues will keep the creativity flowing.
- Be proactive in contacting your supervisor and workmates, and speak up if you need advice or support.
- Stay in the loop by regularly checking the company Intranet and keeping in touch by email, and establishing a mutual feedback process with superiors and colleagues to keep track of progress.
- Keep the communication flowing by organizing virtual coffee dates or water-cooler breaks via messaging tools, video services, or even an internal social network.
- Consider adopting a pet if you are home full time; they make great companions and will always keep you grounded. Dogs make great sounding boards—and pretty much never disagree with you—, while going for walks can be a fantastic source of inspiration.
- Remember that the positive side of isolation is focus!

# STRAIGHT FROM THE LABS OF **PRIMETALS TECHNOLOGIES**

## **SABARI'S LAB**

... was built over the course of 18 months and allows him to pioneer new things.



## **SABARI NATHAN SRIDHAR**

... is conducting a research project to address difficult-to-pickle advanced high-strength steels.



**FIG. 1:** This container houses the pickling simulator, which is used by Sabari to develop new pickling technology.



**FIG. 2:** In order to comply with environmental standards, the simulator only works if the acid-fumes cleaner is turned on.

The extensive R&D efforts of Primetals Technologies are an integral part of the company's larger strategy to continually promote innovation for the metals industry. In this series, we present new, remarkable solutions pioneered by Primetals Technologies' engineers—solutions that may still be in their infancy today but have the potential to change the way steel and other metals will be produced in the decades ahead.

## BETTER PICKLING TECHNOLOGY FOR DEMANDING STEEL GRADES

The moment you meet him, you can tell that Sabari Sri-dhar is a tireless and dedicated researcher. His eyes light up and his energy feels almost electric as he steps into what he calls his "pickling simulator." The story of how the simulator, a tiny yet effective and highly specialized laboratory, came into being, is a long and colorful one. Because it was built on the location of Primetals Technologies Austria in Linz, a large number of permits had to be obtained from the local government. First the construction of the container itself had to be greenlit; then Sabari was asked to demonstrate that all relevant health and safety standards would be met. Dedicated measures had to be taken to address additional environmental concerns: Sabari would be experimenting with acid, and any evaporation had to be proactively prevented. Finally, after 18 months of jumping through regulatory hoops, Sabari was able to conduct his first experiments.

### PICKLING, THE BETTER WAY

Sabari's dedication to the project quickly paid off. The simulator showed that a new pickling technology Sabari and the team had developed actually worked when tested in the real world. "Advanced high-strength steels are difficult to process when it comes to pickling," Sabari says.

"After hot rolling, a layer of iron, silicon, or manganese oxides builds up on the surface of the strip. This is very hard to remove with conventional methods." Sabari made it his mission to pioneer a new approach to pickling.

### DEMANDING STEEL GRADES

Exactly how the innovation by Sabari and his team functions is still top secret. But the technology has already attracted the interest of one of the world's largest steel producers, who is now partnering with Primetals Technologies to advance the development. "I'm really happy with this partnership," says Sabari. "Our partner provided us with samples of novel, next-generation steel grades, which were next to impossible to obtain otherwise." These samples are subjected to the special surface treatment in the pickling simulator, using the same acid as in conventional pickling but to much greater effect. "Advanced high-strength steels are known to be tricky, but they are also in very high demand by the automotive industry," Sabari explains. "They are used for high-end steel applications such as car bodies—very cutting-edge and future-oriented." So do you need a special future-proof permit to make or own them? "Probably many," Sabari says. ●



**FIG. 3:** The simulator comprises an acid tank (to the right), a pump (in red), and an acid chamber (top).



**FIG. 4:** The simulator uses samples of steel strip to compare traditional pickling methods with the newly developed one.





# HOW WILL WE LIVE?

## HYDROGEN: PROPELLING US TOWARD A CLEANER FUTURE

What will tomorrow's world look like—a world that has implemented the innovations pioneered today? A world based on the groundbreaking technological, social, and political ideas that have only just surfaced? In this series, Metals Magazine's independent editor James Gray takes a peek into his crystal ball and lets us know what the future holds.

---

Frequently touted as the “fuel” of the future, I find it fascinating just how many false starts hydrogen has had over the years, dating back to the airships of the early 20th Century and the oft-cited Hindenburg disaster of 1937, which dashed any hopes in hydrogen in a mere 32 seconds, and even beyond that to 200 years ago, when hydrogen powered the first combustion engines. But experts agree that with industries clamoring to move away from fossil fuels in favor of cleaner and more sustainable sources of energy, and the EU striving to become carbon-neutral by 2050, hydrogen's time may finally have come.

Let's get something clear first, though. Although it can be used as a fuel, hydrogen is not an energy source, it is actually a form of energy storage—an energy carrier, similar to electricity, and capable of delivering huge amounts of energy. The production of hydrogen requires another energy source such as natural gas, or renewable electricity if we want to generate “clean” hydrogen. The hydrogen produced is then turned back into energy, which, as I will discuss in this article, can be used almost ubiquitously. The confusion surrounding what exactly hydrogen is has, perhaps, been one of the main reasons why it has struggled to gain traction.

**“ We’ve heard a lot about hydrogen as the energy platform of the future. The familiar joke has been that hydrogen is the energy platform of the future—and always will be.”**

**Stefan J. Reichelstein**

The William R. Timken Professor of Accounting, Emeritus,  
Stanford Graduate School of Business

### WHY THE HYPE—AND WHAT’S THE CATCH?

Hydrogen can be made safely from a variety of fuels including renewables, nuclear, natural gas, coal, and oil. Hydrogen itself is a high-efficiency, low-polluting fuel, a clean energy carrier that produces only water, electricity, and heat when consumed in a fuel cell. Widely versatile, it can be transported as a gas via pipeline—often cheaper than sending electricity over long distances by wire—or in liquid form, and large volumes can be stored easily, for example underground, in tanks as compressed hydrogen, or through chemical compounds that release hydrogen after heating.

At the moment, however, hydrogen use is dominated by industry, primarily oil refining, in agriculture to create fertilizers, and steel production. The lion’s share of this hydrogen is supplied using fossil fuels, and that’s one of the biggest problems. Policymakers agree that clean hydrogen holds huge potential in terms of reducing greenhouse gas emissions. In the U.S.A., only a small fraction of the hydrogen produced is used as an energy carrier, but as leaders all over the world seek to reduce dependence on fossil fuels, hydrogen now represents an attractive and sustainable alternative.

In Europe, hydrogen as a clean fuel can play two key roles as the EU strives to achieve its climate neutrality goals: firstly, enabling greater use of renewable electricity, and secondly decarbonizing CO<sub>2</sub>-intensive sectors, such as chemicals, cement, and steel production. The global steel industry actually produces more CO<sub>2</sub> than steel, with about 1.8 tons of CO<sub>2</sub> released into »

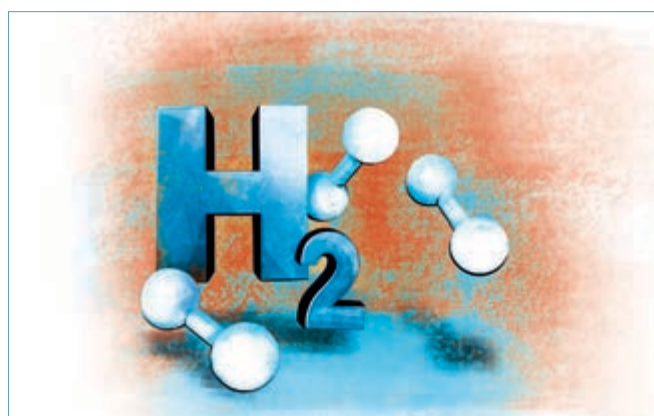

### WHAT IS HYDROGEN?

Hydrogen (H) is the simplest and most abundant element on earth, comprising one proton and one electron, and exists naturally as a molecule. However, because hydrogen as a gas barely exists naturally—it is lighter than air and so rises into the atmosphere—it has to be manufactured from compounds that contain it, such as water, natural gas, or coal, and then stored. Hydrogen has the highest energy content of any fuel by weight, yet the lowest energy content by volume. Hydrogen, like electricity, is an energy carrier; energy carriers are used to move, store, and deliver energy in a usable form.

**“Hydrogen is today enjoying unprecedented momentum. The world should not miss this unique chance to make hydrogen an important part of our clean and secure energy future.”**

**Dr. Fatih Birol**

Executive Director of the International Energy Agency

the atmosphere for every ton of liquid steel, which equates to around 7-10 percent of global CO<sub>2</sub> emissions.

### **THE SPANNER IN THE WORKS**

With hydrogen hailed as the solution to our energy problems, why has progress been so slow? Here we have a high-efficiency, versatile energy carrier with the potential to provide clean, safe, and affordable energy, and after all, hydrogen is the most abundant element in the universe, right? The problem lies in a fact we touched upon earlier, that hydrogen does not naturally exist on Earth in its elemental form and so has to be produced from compounds that contain hydrogen in processes that require a lot of energy in the first place.

Almost all hydrogen for industrial use is currently produced using fossil fuels, and—as Tesla CEO Elon Musk has pointed out, dismissing fuel cells as “fool cells”—, it takes a huge amount of energy to turn hydrogen into useable fuel. Hydrogen production can be split into three main categories: thermal, electrolytic (the most common method), and photolytic processes. Thermal processes rely on the energy in natural gas, coal, or biomass in order to produce hydrogen, and include natural gas reforming, gasification, renewable liquid fuel reforming, and high temperature water splitting. Electrolytic processes split water into hydrogen and oxygen using electricity, while photolytic processes do the same using light energy.

Another issue is that in order to efficiently and cost-effectively move hydrogen from its point of production and deliver it to points of end use, such as vehicle refueling stations, an appropriate infrastructure (pipelines, trucks, rail routes, etc.) first has to be put in place.

### **GAINING MOMENTUM**

Hydrogen is a versatile energy carrier that already has multiple applications and, according to a report by the International Energy Agency (IEA), it is building “unprecedented momentum”. The fuel cell, which is an energy-conversion device designed to convert and use the power of hydrogen, ideally in a highly efficient way, is crucial. Hydrogen can be used to power vehicles, as well as homes and offices, and even portable electronic equipment such as laptops or generators. Stationary hydrogen fuel cells can be used to power critical facilities such as hospitals and data centers, and to provide backup power for regional emergency shelters, telecommunications in remote locations, remote weather stations, or to supply power to rural locations that are not connected to the electric power grid.

### **POWER TO THE PEOPLE**

Hydrogen-powered cars have perhaps stolen the limelight, but beyond powering all types of vehicles, there are other exciting ways that hydrogen fuel cells are already being used. Stationary applications that produce electricity and heating are one such innovation. In stationary fuel cell configurations, the fuel cells are either





**FIG. 1:** The zero-emission Coradia iLint is the world's first hydrogen fuel cell-powered passenger train, and winner of the prestigious GreenTec Mobility Award in 2018.

connected directly to the power grid or installed as grid-independent generators of electricity or heating.

Asia is at the forefront of this green technology with a number of groundbreaking initiatives. The Gyeonggi Green Energy fuel cell park in Hwasung City, South Korea, is the largest fuel cell park in the world. It consists of 21 fuel cells and boasts a total output of 59 megawatts of electricity, delivering ultra-clean, renewable power to the grid and usable heat to a district heating system. The world's first hydrogen fuel cell power plant, located in Daesan, South Chungcheong Province, is designed to deliver by-product hydrogen via underground pipelines. It generates 400,000 megawatt-hours of electricity to power 160,000 households every year.

South Korea has its sights set on creating the first hydrogen-powered society and has announced ambitious plans to build three hydrogen-powered cities by 2022. The cities will use hydrogen as the fuel for cooling, heating, electricity, and transportation systems. The plan is part of a broader strategy to power 10 percent of South Korea's cities, counties, and towns with hydrogen by 2030, with a further push to 30 percent by 2040.

### ALL ABOARD

I would stick my neck out and say that transportation is one of the more exciting areas for the application of hydrogen technologies, and Europe already has a head

start. The world's first hydrogen-powered train has been operating commercially in Lower Saxony, Germany, since 2018 already. The Coradia iLint is a zero-emission regional passenger train that emits only steam and condensed water. The iLint boasts clean energy conversion, flexible energy storage in batteries, and smart management of traction power, and is designed for non-electrified lines. The high-performance train has also been carrying passengers for the Austrian Federal Railways, for a three-month stint that ended in November 2020.

### FLIGHT OF FANCY?

So what does the future hold? As I mentioned, I believe that transportation is the big one, but that covers a wide area, from passenger vehicles to commercial trucks, buses, trains, and shipping. I am prepared to speculate that the real potential for hydrogen—in the transportation sector, at least—lies in aviation. The advantage hydrogen has over let's say battery technology is its unbeatable energy-to-weight ratio, owing to its exceptionally low density. It is for this reason that hydrogen is favored by NASA for its space programs.

The aviation industry, having once ditched hydrogen in favor of biofuels from sustainable sources, and because of the massive energy costs involved in making hydrogen, is now revisiting the technology. Back in 2000, aerospace giant Airbus was involved in the





**FIG. 2:** Airbus has thus far unveiled three hydrogen-powered plane concepts. The futuristic blended-wing version (pictured) could fly up to 200 passengers distances of 2,000 miles.

## WHAT IS A FUEL CELL?

While fuel cells are similar to batteries, producing electricity without combustion or emissions, they do not run down or need recharging, providing there is a continuous supply of fuel and oxygen. A single fuel cell comprises an electrolyte between two electrodes, an anode and a cathode, and its job is to directly convert the chemical energy in hydrogen into electricity and heat. Within the fuel cell, hydrogen electrochemically combines with oxygen to create electricity, and the only byproducts are pure water and useful heat, which is what makes this technology so attractive. Not only are fuel cells zero-pollution devices, they are also two to three times more efficient than conventional internal combustion technologies. The grid-independence of fuel cells also makes them ideal for powering facilities such as data centers, hospitals, and emergency response systems, where continual power is critical.

26-month, EC-funded Cryoplane project to evaluate liquid hydrogen as a means of powering the zero-carbon-emissions aircraft of the future. The upshot was that aircraft would require fuel tanks four times larger than traditional tanks, and the resulting larger exterior surface areas would increase energy consumption at least tenfold.

Now Airbus has revealed plans for the potentially first commercial zero-emission aircraft and is bullish that its hydrogen-fueled passenger planes could be in service by 2035. Airbus has produced three concept designs—codenamed ZEROe—that align with its stated ambition to decarbonize the entire aviation industry: a turbofan design capable of carrying up to 200 passengers more than 2,000 miles, a short-haul turboprop concept, and a “blended-wing body” design. All three would use gas-turbine engines burning liquid hydrogen, and hydrogen fuel cells would produce electrical power. The biggest stumbling block, says Airbus, is the massive investment required from airports in a refueling infrastructure.

Meanwhile in Bedfordshire, U.K., a small hydrogen-powered commercial aircraft from ZeroAvia has already taken to the skies: a six-seater Piper M-class plane powered by a hydrogen-electric engine. The

## A HYDROGEN STRATEGY FOR A CLIMATE NEUTRAL EUROPE

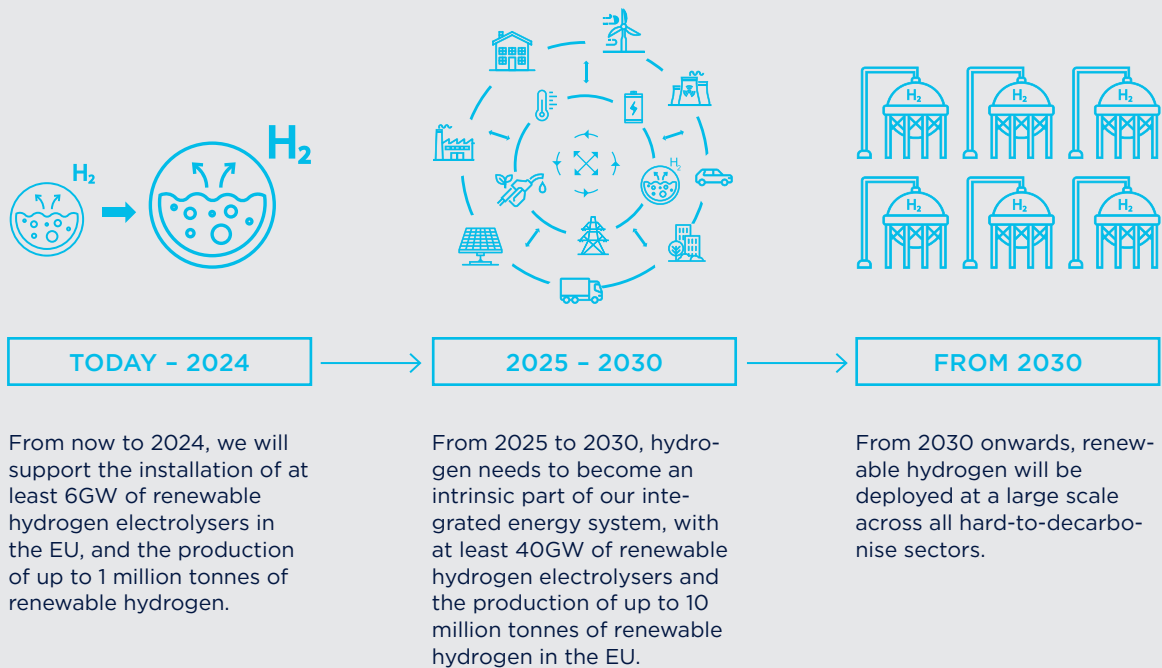

**FIG. 3:** Source: European Commission, "A Hydrogen Strategy for a Climate-Neutral Europe." Visit [meta.is/euhydrogen](https://meta.is/euhydrogen) for further reading.

company is aiming to make hydrogen planes commercially available within three years, and claims that the science for a long, zero-emissions flight by the end of this decade already exists. In this case, too, an overhaul of ground-operations infrastructure would be essential. ZeroAvia's project has the backing of the U.K. government as part of the Jet Zero Council initiative, geared toward making net-zero emissions flights a reality.

### I WANNA BE A ROCKSTAR

Frans Timmermans, First Vice-President of the European Commission and Executive Vice-President for the European Green Deal, speaking at the launch of the Hydrogen Strategy, eulogized hydrogen as "the rockstar for new energies all across the world". The ambitious Hydrogen Strategy is geared toward decarbonizing the economy through the use of clean hydrogen produced using wind and solar energy in order to

achieve climate neutrality by 2050. Although demand for hydrogen is undoubtedly on the increase, production is still responsible for CO<sub>2</sub> emissions of around 830 million tons per year. Not only that, the cost of production itself needs to be brought down drastically. If hydrogen is to make a significant contribution to clean energy transitions, it needs to be adopted in sectors where it is virtually absent, like long-haul transport, chemicals, iron and steel, buildings, and power generation, where infrastructures are still woefully inadequate.

One thing is clear: the development of technologies geared toward producing hydrogen at lower cost, combined with building an infrastructure capable of both efficiently and cost-effectively storing and delivering hydrogen while also making it easy to use, will require a global effort across many industries and sectors. Only then will hydrogen become commercially viable. Governments, renewable electricity suppliers, car manufacturers, and oil and gas companies, are all throwing their considerable weight behind hydrogen technologies, while investments will inevitably boost economies around the world and create skilled jobs. All the signs are that the benefits clearly outweigh the costs—so as I gaze into my trusty crystal ball, I confidently predict that this time around, we are not on the brink of another false dawn. We will have lift-off. ●



#### HYDROGEN IN IRONMAKING

Scan the QR code or follow the link to learn more about how hydrogen is impacting the steel industry.

[meta.is/zerociron](https://meta.is/zerociron)





# ASK DR. HIRAI

## YOUR QUESTIONS FOR THE CTO OF PRIMETALS TECHNOLOGIES

In this section, Dr. Etsuro Hirai, CTO of Primetals Technologies, exclusively answers your questions. Should there be an issue that you would like him to address, please send us an email containing your question, your job title, and your location.

Email address for questions:  
[ask-the-expert@primetals.com](mailto:ask-the-expert@primetals.com)

### WHAT IS THE SINGLE GREATEST BENEFIT OF DIGITALIZATION IN STEEL PRODUCTION?

Asked by a customer from China

**Dr. Etsuro Hirai:** If implemented correctly, digital solutions can help steel producers to increase productivity and to ensure long-term profitability. But it is important to remember that this goal can only be reached if the new digital technologies are combined with state-of-the-art production equipment. In other words, the digital and the mechanical sides of steel production need to come together to form a powerful unity. Let me give you an example: Arvedi Endless Strip Production is highly innovative on the mechanical side; never before has endless thin-slab casting and rolling been this compact, energy-efficient, and environmentally compatible. We are now developing a digital twin of Arvedi ESP so that sophisticated simulations can be made and product development becomes much easier and faster. This enables producers to better react to specific customer orders of new steel grades. Digitalization also allows for better quality control, which is highly complex especially when producing advanced high-strength steels or electrical steels.

### WHAT ARE THE BENEFITS OF COLLABORATING WITH STEEL PRODUCERS REMOTELY—VIA VIDEO LINK?

Asked by an industry partner in Japan

**Dr. Hirai:** In the time of Covid-19, the most obvious benefit is that remote collaborations minimize risk and ensure

the health and safety of those involved. Thanks to remote connections, we can provide producers with seamless support and online training sessions. Remote monitoring has become a reality for many steel plants worldwide, and remote maintenance and commissioning are also on the rise. The ultimate target is the "remote factory," where everything can be controlled from afar. For now, some work still has to be done manually—specifically when it comes to hardware implementations. But once the setup is complete, more and more processes will lend themselves to being executed remotely.

### HOW CAN METALS PRODUCERS PREPARE FOR A LOW-CARBON ECONOMY?

Asked by a customer from the U.S.A.

**Dr. Hirai:** At the moment, the best strategy is to aim for flexible production routes in iron- and steelmaking. In the next few decades, the blast-furnace to converter route, which currently represents around 70 percent of global steel production, will increasingly shift to electric steelmaking. Direct reduction will become even more relevant, and we are happy to be partnering with Midrex in this regard. Midrex currently relies on natural gas, but eventually hydrogen will become an option. The hurdle for that to happen is not technological but economical in nature. In the long term, our HYFOR technology will enable hydrogen-based fine-ore reduction for absolutely green ironmaking, and carbon capture and storage as well as carbon utilization can be part of a greener strategy. ●



**Publisher:** Primetals Technologies, Ltd., Chiswick Park, Building 11, 566 Chiswick High Road, W4 5YS, London, United Kingdom

**Metals Magazine team:** Dr. Tom Widter, Editor-in-Chief; Alexander Reindl, Art Director; Martin Reitbauer, Editor; James Gray, Independent Contributor and Editor; Dr. Lawrence Gould, Fmr. Managing Editor; Dr. Rainer Schulze, Contributing Editor; Stefan Thiel: Illustrator

**Publishing house:** Red Sam Media GmbH, [www.redsam-media.at](http://www.redsam-media.at)

**Publication date:** February 2021

**Circulation:** 8,000 copies

**ISSN:** 2194-5381

**Cover page:** Original image via shutterstock.com (Vit-Mar); cover design by Primetals Technologies and Red Sam Media

**Images:** All content by Primetals Technologies, unless otherwise indicated and with the following exceptions:

Page 1, 5, 18-19, 116: shutterstock.com (Vit-Mar);

Pages 3, 7: Robert Josipovic;

Page 9: Outokumpu;

Page 13 (second image): Kappa Filter Systems;

Page 29: HBIS Group;

Page 78-79: istock.com (JazzIRT);

Pages 92-93 (photos 1, 2, 4 of series): Ternium Brazil;

Page 96, 99: public domain;

Pages 100, 105: shutterstock.com (Halfpoint, fizkes);

Page 111: Alstom;

Page 112: Airbus

**List of registered products:** ChatterBlock, Connect & Cast, COREX, CTC Caster Technology Consulting, DRIPAX, DSR, DYNACS, DynaGap SoftReduction, EAF FAST DRI, EAF Quantum, ERT-EBROS, FAPLAC, FINEX, Gimbal Top, HCMILL, HCMW, HCX, HYPER UCM, HYPER UCMILL, HYROP, iBox, idRHa+, IMGS, IT4Metals, JETFINE, KL, KLX, KZR, LIQUIROB, LOMAS, MEROS, MORGUIL, MORSHOR, MQL, NO-TWIST, Pioneers at Heart, PLANICIM, Red Ring, RSM, Sheetflat, SIAS, Si-Filter, SMART, SmartCrown, SR SERIES, STELMOR, TCOptimizer/TCOPTIMIZER, UCM, UCMILL, UCMW, WinLink, X-HI, Xline are registered trademarks of Primetals Technologies, Ltd. in certain countries.

- CSP is a registered trademark of SMS Siemag AG.
- EBROS is a registered trademark of Steel Plantech Co.
- EMSpec, a registered product of the University of Manchester, U.K., is exclusively licensed to Primetals Technologies, Ltd.
- HYQST is a trademark of Siemens Industry, Inc.
- MIDREX, DRIPAX are registered trademarks of Midrex Technologies, Inc.
- MULPIC is a registered trademark of Centre de Recherches Métallurgiques ASBL.
- SCR is a registered trademark of Southwire Company, LLC.
- SVC Plus is a registered trademark of Siemens AG.

All figures and values cited in this issue of Metals Magazine are in metric units unless otherwise indicated.

© 2021 Primetals Technologies, Limited

All rights reserved by the publisher.

For inquiries and more information:

[contact@primetals.com](mailto:contact@primetals.com)



Elements of this cover will glow in the dark if charged with UV-rich light.

---

For inquiries and more information:  
**[contact@primetals.com](mailto:contact@primetals.com)**